

RACORES AUTOMÁTICOS

Los racores automáticos Metal Work representan el elemento de conjunción tubo-actuador por excelencia. Práctico y veloz el racor automático Metal Work se puede re-utilizar miles de veces sin comprometer la perfecta retención neumática y mecánica. Disponible en diversas configuraciones, asegura una flexibilidad de empleo prácticamente ilimitada; el muelle de sujeción, prende el tubo sin grabarlo ni deformarlo permitiendo así una mayor simplicidad en la operación de conectar o desconectar el racor del tubo. En los racores el anillo del racor dispone de unas ranuras para el destornillador (PATENT.) para facilitar la desconexión en aplicaciones inaccesibles a los dedos, además las figuras RL19, RL21, RL22, RL23, RL23M, RL24, RL44, RL45 y RL49 ofrecen la posibilidad de fijación a pared gracias a dos agujeros pasantes asimétricos.



DATOS TÉCNICOS		
Roscas		M3 - M5 - M7 - 1/8" - 1/4" - 3/8" - 1/2"
Diámetros	mm	∅ 3 - ∅ 3,17 - ∅ 4 - ∅ 5 - ∅ 6 - ∅ 8 - ∅ 10 - ∅ 12 - ∅ 14
Rango de temperaturas para racores de latón	°C	-20°C +80°C
	°F	-4°F ÷ 162°F
Rango de temperaturas para racores de tecnopolímero	°C	-20°C +60°C
	°F	-4°F ÷ 132°F
Rango de presión racores de latón		-0,99 bar ... 16 bar / -0,099 MPa ... 1,6 MPa
Rango de presión racores de tecnopolímero		-0,99 bar ... 12 bar / -0,099 MPa ... 1,2 MPa
Tubo recomendado		Rilsan PA11, Nylon 6, Poliamida 12, Polipropileno.
Fluido		Vacio - Aire comprimido

COMPONENTES

- ① Anillo o casquillo de acoplamiento: tecnopolímero
- ② Casquillo de bloqueo: tecnopolímero
- ③ Cuerpo: latón o tecnopolímero
- ④ Muelle de sujeción: acero inox (para tubos ∅ 3 y ∅ 3,17 y R31 ∅5 y R32 ∅5: pinza en latón)
- ⑤ Anillo soporte del muelle: tecnopolímero.
- ⑥ Juntas de retención: NBR

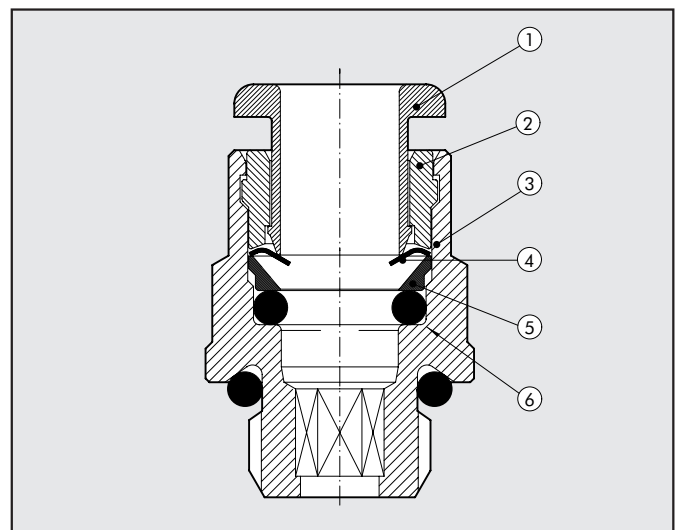



SOLO PARA LOS RACORES AUTOMÁTICOS Ø 8

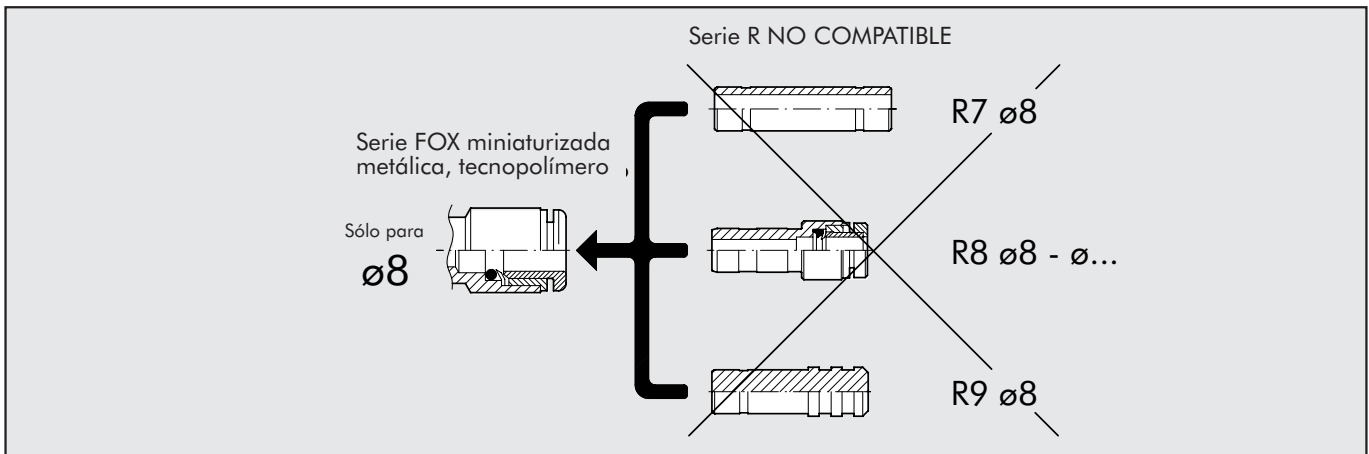

La nueva serie de racores automáticos miniaturizados del diámetro 8 identificables por la letra L en el código del artículo y distinguible también por las ranuras en el anillo para destornillador, no son compatibles con los racores R7, R8 y R9 diámetro 8 de la serie R.

JUNTAS O-RING BASE DEL RACOR

Rosca	Referencia	Medidas O-ring	Rosca	Referencia	Medidas O-ring
M3	2.6x1	1/8	2031	7.66x1.78
M5 (para Ø 3 - Ø 3.17)	3x1.2	1/4	2043	10.82x1.78
M5	3.5x1.2	3/8	2056	14x1.78
M7	5x1.5	1/2	3068	17.13x2.62
M12x1,5	9.75x1.78			

TIPO DI AVVITATURA

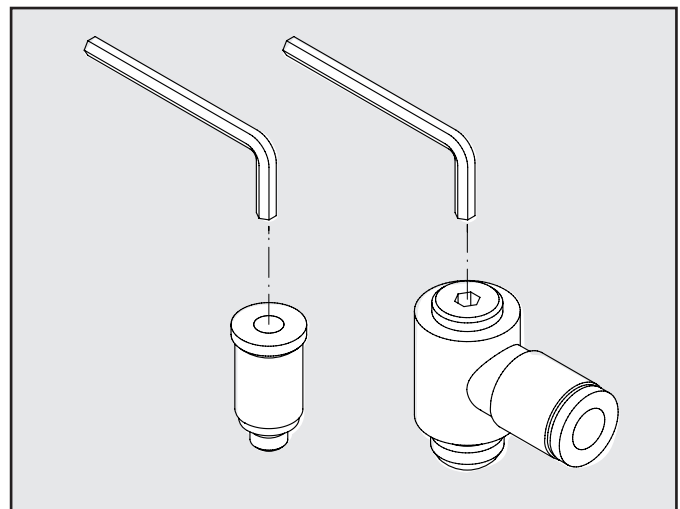
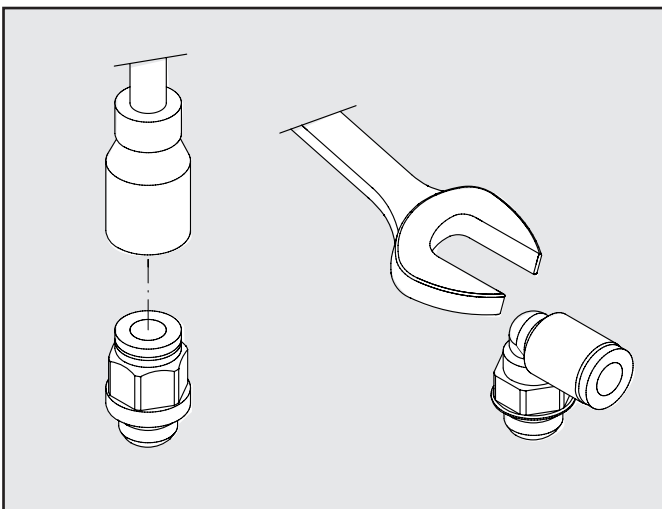

Roscas	Apriete MAX [Nm]
M3	0.4
M5	1.8
M7	2.5
M12x1,5	8
G 1/8"	6
G 1/4"	8
G 3/8"	10
G 1/2"	15

CH [mm]	Apriete MAX [Nm]
1.5	0.4
2	0.7
2.5	1.2
3	2.5
4	5
5	8
oltre 5	ver valori relativi a roscas

NB: Para el montaje tramite llave o vaso-llave, el valor de la fuerza de apriete no debe superar los indicados en las roscas. (ejemplo el record RL1 6 M7, con una llave interna de 4 mm va con fuerza de apriete max. 2,5 Nm)

CARACTERISTICAS GENERALES

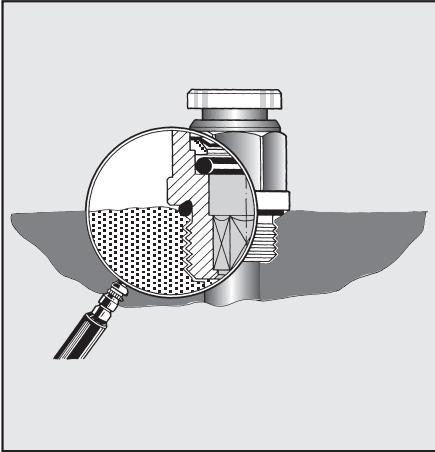

Todos los rcores con rosca cilndrica y junta de estanqueidad incorporada (patente METAL WORK). El uso del OR mejora claramente la estanqueidad en las superficies inclinadas, brutas, ligeramente convexas, etc. Eliminacin del uso del Teflon (PT.FE.).

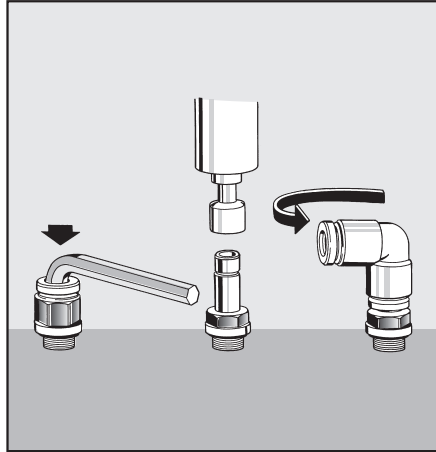

Montaje de los rcores con llaves Allen o con til neumtico. Todas las L y T son giratorias. Drstica reduccin del tiempo de montaje.

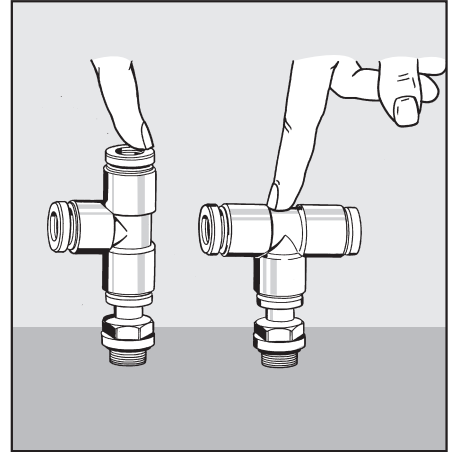

Con una sola T se realizan las T centrales y las T laterales.

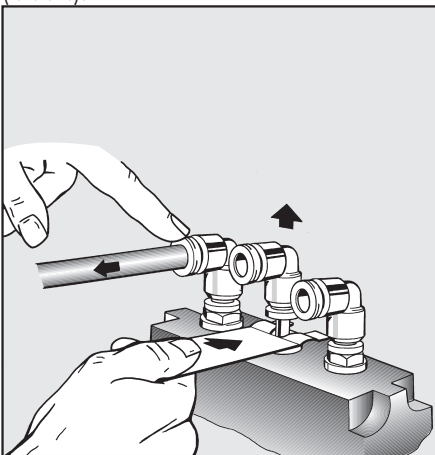

Facilidad de desmontaje del tubo mediante una ligera presin sobre el anillo de empuje. Prctico desmontaje del rcor con una simple presin radial sobre la llave de desmontaje.

DE UNA IDEA UN SISTEMA

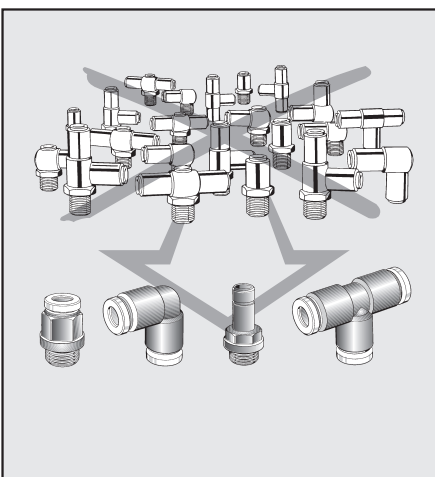

- Con cuatro rcores base se realizan todas las conexiones de un circuito neumtico.
- Drstica disminucin de los rcores a mantener en el almacn y de los correspondientes costes de gestin.



ESQUEMA DE MONTAJE

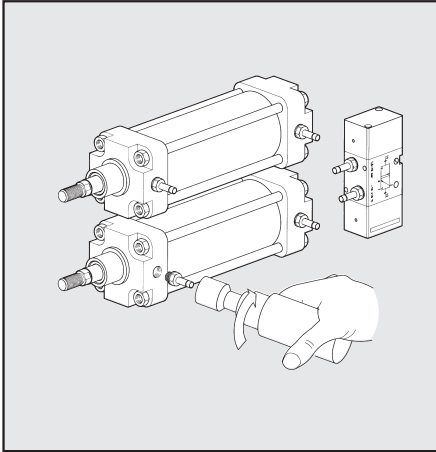

Premontaje de los rácores con útiles neumáticos también con entrejes muy próximos.

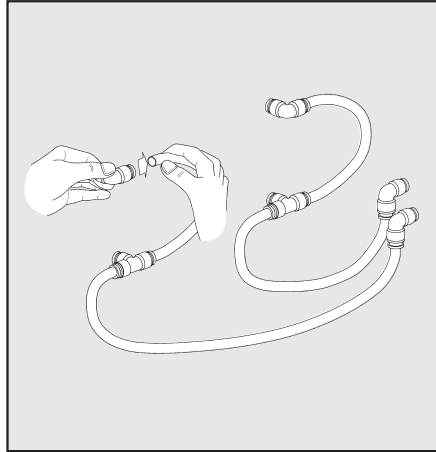

Premontaje de los rácores con los segmentos de tubo. Posibilidad de almacenar configuraciones premontadas para montaje en serie.

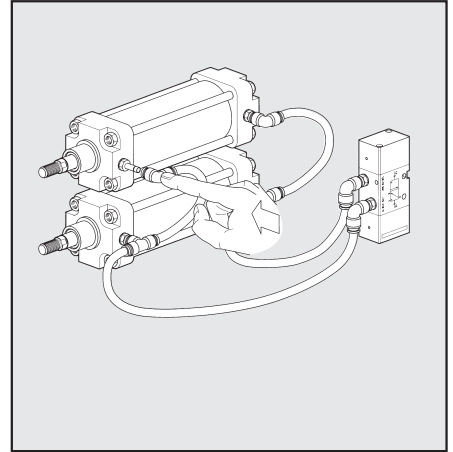

Rápida conexión y finalización del circuito neumático.

DA UN SISTEMA UN INNOVAZIONE

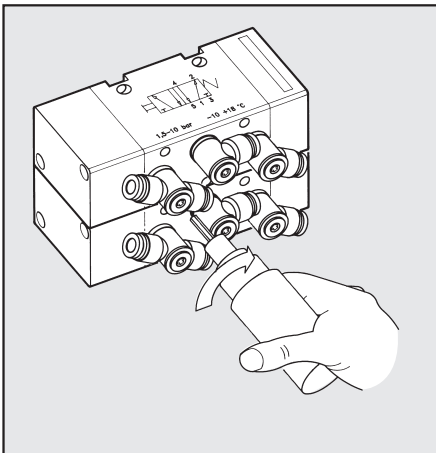

La llave Allen permite montar los rácores giratorios incluso con los interjes muy próximos.

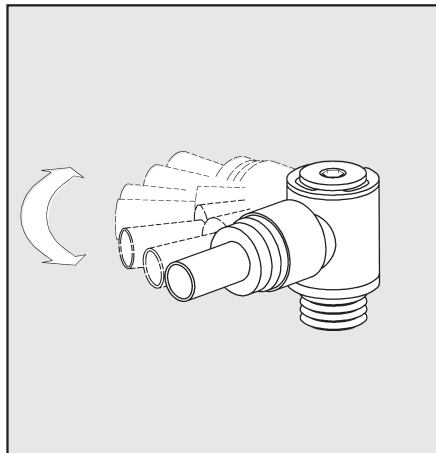

La especial solución constructiva con doble "OR" de estanqueidad, permite aprovechar la orientabilidad también para seguir el movimiento del tubo en el contexto de la automatización específica.

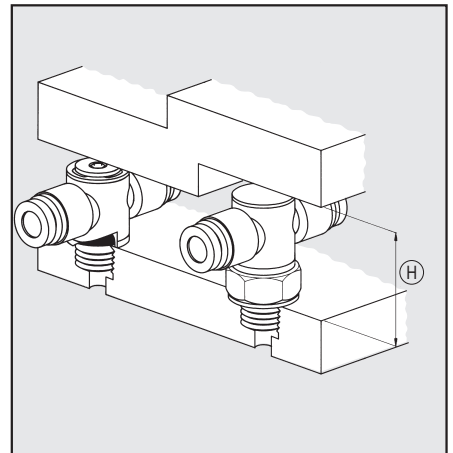

Rácores con junta incorporada y altura (H) reducida con paridad a la conexión roscada y Ø tubo.

RACORES AUTOMÁTICOS

RECTO CILÍNDRICO MACHO (R1)

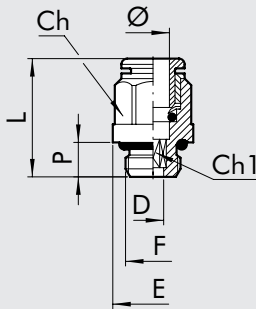

Cód.	Ref.	Ø	F	Ch	Ch1	P	L	D	E
2001B01	R1	3	M3	Ø 5.8	1.5	3	12.6	1.5	5.8
2001B02	R1	3	M5	Ø 5.8	2	3.5	13	2	5.8
2001A01	R1	3.17	M3	Ø 5.8	1.5	3	12.6	1.5	5.8
2001A02	R1	3.17	M5	Ø 5.8	2	3.5	13	2	5.8
2L01001	RL1	4	M5	Ø 9	2.5	4	20.3	2.6	9
2L01020	RL1	4	M7	Ø 9	3	5	18.9	3.1	9.8
2L01002	RL1	4	1/8	10	3	6	18	3.1	14
2L01003	RL1	4	1/4	10	3	8	19.8	3.1	18
2001004	R1	5	M5	Ø 12	2.5	4	22.5	2.6	12
2001005	R1	5	1/8	13	3	6	22	3.1	15
2001006	R1	5	1/4	12	3	8	24	3.1	18
2L01000	RL1	6	M5	Ø 11	2.5	4	21.9	2.6	11
2L01021	RL1	6	M7	Ø 11	4	5	23	4.1	11
2L01101	RL1	6	M12x1.5	12	4	8	23.2	4.1	17
2L01007	RL1	6	1/8	12	4	6	21.6	4.1	14
2L01008	RL1	6	1/4	12	4	8	20.3	4.1	18
2L01102	RL1	8	M12x1.5	14	6	8	24.5	6.2	17
2L01009	RL1	8	1/8	13	5	6	25.4	5.2	14
2L01010	RL1	8	1/4	14	6	8	24.4	6.2	18
2L01011	RL1	8	3/8	14	6	9	22.8	6.2	22
2L01012	RL1	10	1/4	16	7	8	29.2	7.2	18
2L01013	RL1	10	3/8	16	8	9	26.5	8.2	22
2L01018	RL1	10	1/2	16	8	11	29.8	8.2	26
2001019	RL1	12	1/4	19	7	8	30.5	7.2	21
2001014	RL1	12	3/8	19	10	9	28.1	10.2	22
2001015	RL1	12	1/2	19	10	11	29.3	10.2	26
2001016	RL1	14	3/8	22	10	9	33.8	10.2	24.6
2001017	RL1	14	1/2	22	12	11	31.5	12.2	26

RECTO CÓNICO MACHO (R1C)

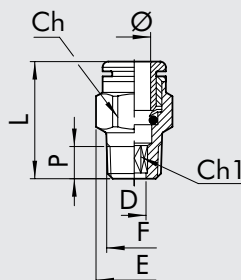

Cód.	Ref.	Ø	F	Ch	Ch1	D	E	L	P
2L01C02	RL1C	4	1/8	10	3	3.1	11.3	18.5	6.2
2L01C07	RL1C	6	1/8	12	4	4.1	13.5	22.5	6.2
2L01C08	RL1C	6	1/4	12	4	4.1	13.2	22.3	8.5
2001Z07	RL1Z	6	12x1 con.	12	4	4.1	13.2	23.5	9
2001Z08	RL1Z	6	12x1.25 con.	12	4	4.1	13.2	23.5	9
2L01C09	RL1C	8	1/8	13	6	6.2	14.3	26	6.2
2L01C10	RL1C	8	1/4	14	6	6.2	15.8	25.5	8.5
2L01C11	RL1C	8	3/8	14	6	6.2	16.6	24.9	9
2L01C13	RL1C	10	1/4	16	7	7.2	17.7	28.9	8.5
2L01C14	RL1C	10	3/8	16	8	8.2	17.7	26	9
2001C15	RL1C	12	3/8	19	10	10.2	21	28.5	9
2001C16	RL1C	12	1/2	19	10	10.2	21.3	26.6	11



RECTO HEMBRA (R2)

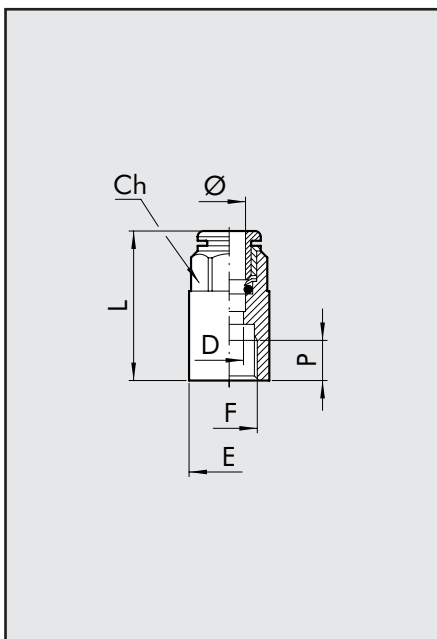

Cód.	Ref.	Ø	F	Ch	P	L	D	E
2002B02	R2	3	M5	7	4.5	15.7	2.5	7.8
2002A02	R2	3.17	M5	7	4.5	15.7	2.5	7.8
2L02001	RL2	4	1/8	10	7	26.2	3	14
2L02002	RL2	4	1/4	10	8	28.6	3	17
2002003	R2	5	1/8	12	7	27	4	14
2002004	R2	5	1/4	12	8	29.5	4	17
2L02005	RL2	6	1/8	12	7	27.1	5	14
2L02006	RL2	6	1/4	12	8	29.3	5	17
2L02007	RL2	8	1/8	13	7	28.1	7	14
2L02008	RL2	8	1/4	14	8	30	7	17
2L02009	RL2	10	1/4	16	8	31.8	8	17.7
2L02010	RL2	10	3/8	16	10	36.8	8	20.8
2L02011	RL2	12	3/8	19	10	37	10	20.8
2L02012	RL2	12	1/2	19	11	40.5	10	23.8

RECTO INTERMEDIO (R3)

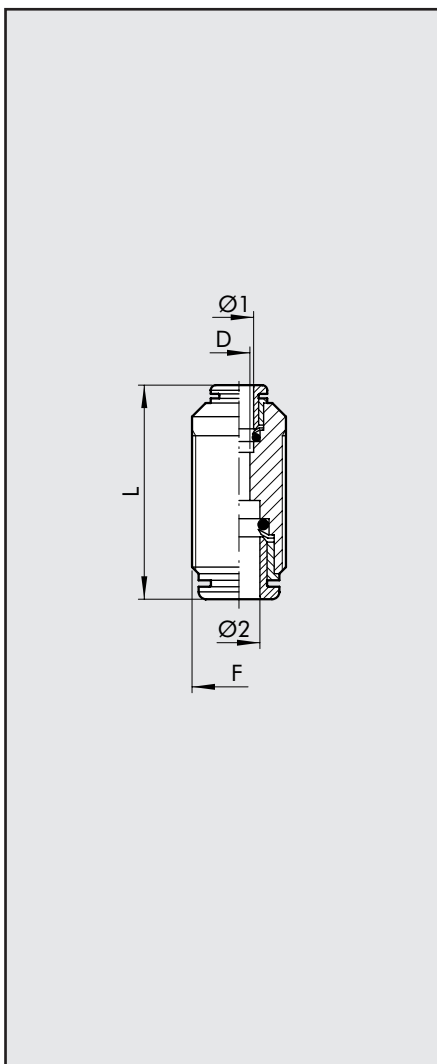

Cod.	Ref.	Ø1	Ø2	F	L	D
2003A02	R3	3	3	M8x0.75	18.4	2
2003A01	R3	3.17	3.17	M8x0.75	18.4	2
2L03001	RL3	4	4	M11x1	30.6	2.5
2003002	R3	5	5	M14x1	33.5	4
2L03003	RL3	6	6	M13x1	33	4.5
2L03004	RL3	8	8	M15x1	35.7	6.5
2L03005	RL3	10	10	M17x1	39.2	8
2003006	RL3	12	12	M20x1	40.7	10
2003007	RL3	14	14	M24x1	45.9	12
2L03301	RL3	4	6	M13x1	32.7	2.5
2L03302	RL3	4	8	M15x1	34.4	2.5
2L03303	RL3	6	8	M15x1	35	4.5
2L03304	RL3	6	10	M17x1	37.5	4.5
2L03306	RL3	6	12	M20x1	39	4.5
2L03305	RL3	8	10	M17x1	37.8	6.5
2L03307	RL3	8	12	M20x1	40.1	6
2L03308	RL3	10	12	M20x1	40.8	8

L INTERMEDIO (R4)

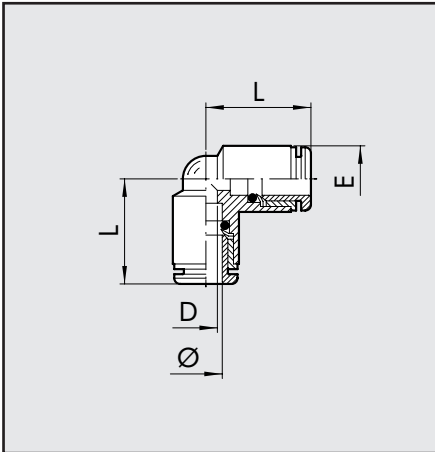

Cód.	Ref.	Ø	L	D	E
2004A02	R4	3	10.4	2	6.3
2004A01	R4	3.17	10.4	2	6.3
2L04001	RL4	4	16.7	2.5	9.5
2004002	R4	5	19.2	3	13.5
2L04003	RL4	6	19	4.5	11.5
2L04004	RL4	8	21.3	6.5	13.5
2L04005	RL4	10	23.3	8	16
2004006	RL4	12	26	10	20.5
2004007	RL4	14	29.3	12	22

T INTERMEDIO (R5)

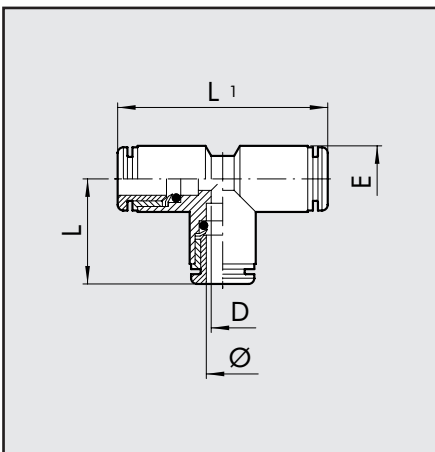

Cód.	Ref.	Ø	L	L1	D	E
2005A02	R5	3	10.4	20.8	2	6.3
2005A01	R5	3.17	10.4	20.8	2	6.3
2L05001	RL5	4	16.7	33.4	2.5	9.5
2005002	R5	5	19.2	38.4	3	13.5
2L05003	RL5	6	19	38	4.5	11.5
2L05004	RL5	8	21.3	42.6	6.5	13.5
2L05005	RL5	10	23.3	46.6	8	16
2005006	RL5	12	26	52	10	20.5
2005007	RL5	14	29.3	58.6	12	22

ADAPTADOR ROSCADO (R6)

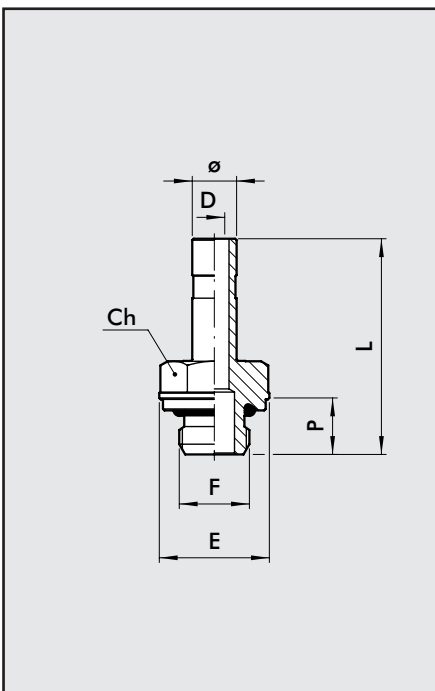

Cód.	Ref.	Ø	F	Ch	P	L	D	E
2006A02	R6	3	M5	5	3.5	17.1	2	5.8
2006A01	R6	3.17	M5	5	3.5	17.1	2	5.8
2006001	R6	4	M5	8	4	25.2	2.5	9
2006020	R6	4	M7	8	5	26.5	2.5	9.8
2006002	R6	4	1/8	13	6	28.9	2.5	15
2006003	R6	4	1/4	14	8	32.4	2.2	18
2006004	R6	5	M5	8	4	25.2	2.7	9
2006005	R6	5	1/8	13	6	28.9	3	15
2006006	R6	5	1/4	14	8	32.4	3	18
2006000	R6	6	M5	9	4	25.7	2.7	10
2006021	R6	6	M7	8	5	27	4	9.8
2006007	R6	6	1/8	13	6	29.4	4	15
2006008	R6	6	1/4	14	8	32.9	4	18
2006009	R6	8	1/8	13	6	30.6	5.5	15
2006010	R6	8	1/4	14	8	34	6	18
2006011	R6	8	3/8	17	9	35.4	6	22
2006012	R6	10	1/4	14	8	38.2	7.8	18
2006013	R6	10	3/8	17	9	38.7	8	22
2006022	R6	10	1/2	19	11	41	8	26
2006019	R6	12	1/4	14	8	40.7	7.8	18
2006014	R6	12	3/8	17	9	42.2	10	22
2006015	R6	12	1/2	22	11	44.2	10	26
2006016	R6	14	3/8	17	9	46.2	10	22
2006017	R6	14	1/2	22	11	48.2	12	26
2006101	R6	6	M12X1.5	13	8	33	4	17
2006102	R6	8	M12X1.5	13	8	33.7	6	17



ADAPTADOR ROSCADO PROLONGADO (R18)

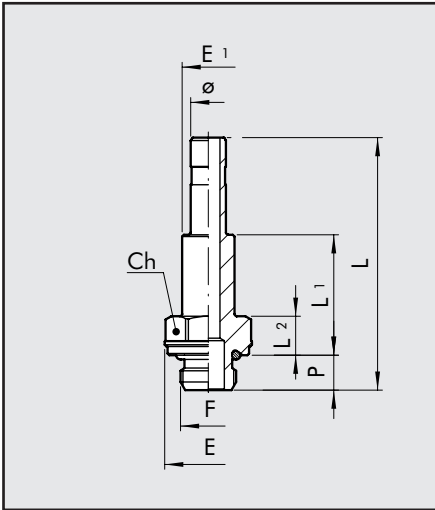

Cód.	Ref.	Ø	F	Ch	P	L	L1	L2	E	E1
2018002	R18	4	1/8	13	6	40.4	18.2	6.7	15	7
2018007	R18	6	1/8	13	6	43.4	20.7	6.7	15	9
2018008	R18	6	1/4	14	8	46.9	22.2	8.2	18	9
2018009	R18	8	1/8	13	6	46.5	22.7	6.7	15	11
2018010	R18	8	1/4	14	8	50	24.2	8.2	18	11
2018011	R18	8	3/8	17	9	51.4	24.7	8.7	22	13
2018012	R18	10	1/4	14	8	57.2	27.2	8.2	18	12
2018013	R18	10	3/8	17	9	58.7	27.7	8.7	22	12

PROLONGACIÓN (R7)

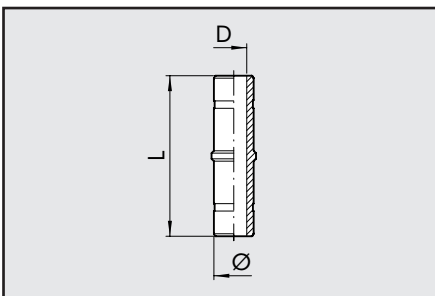

Cód.	Ref.	Ø	L	D
2007001	R7	4	34	2
2007002	R7	5	34	3
2007003	R7	6	37.5	4
2L07004	RL7	8	37.5	6
2007005	R7	10	45	8
2007006	R7	12	48	10
2007007	R7	14	58	12

REDUCCIÓN (R8)

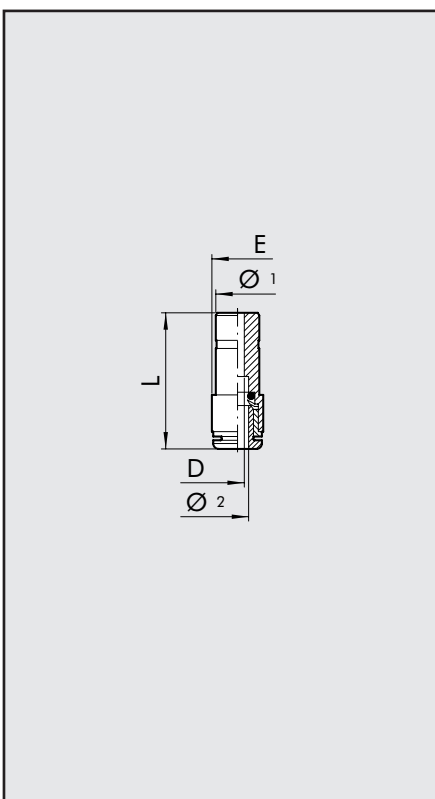

Cód.	Ref.	Ø1	Ø2	L	D	E
2008A01	R8	4	3	26	2	6.3
2008A02	R8	4	3.17	26	2	6.3
2008001	RL8	5	4	32.2	3	9.5
2L08002	RL8	6	4	29.9	2.8	9.5
2008003	R8	6	5	36	4	12
2L08004	RL8	8	4	28.7	2.8	9.5
2008005	R8	8	5	34.5	4	12
2L08006	RL8	8	6	31.9	4.5	11.5
2L08007	RL8	10	6	36.2	5	11.5
2L08008	RL8	10	8	40.8	7	14
2008009	RL8	12	4	36.7	3	13
2008010	RL8	12	6	42	5	13
2008011	RL8	12	8	40.1	7	14
2008015	RL8	12	10	44.3	8.2	16
2008014	RL8	14	8	44.1	7	15.5
2008017	RL8	14	10	44.3	8.2	16
2008018	RL8	14	12	50	10	19.5
AUMENTO						
2009001	RL8/M	4	6	34.5	2.5	11.5

TAPÓN (R9)

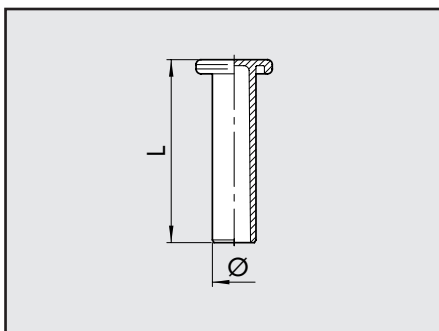

Cód. Ref. Ø L

2010A02	R9	3	20
2L10A01*	RL9T	3.17	19.6
2L10001*	RL9T	4	27
2010002	R9	5	27
2L10003*	RL9T	6	29.8
2L10004*	RL9T	8	33.6
2L10005*	RL9T	10	36.8
2L10006*	RL9T	12	39
2010007	R9	14	39.5

* FABRICADO EN TECNOPOLIMERO

RECTO INTERMEDIO PASATABIQUES (R10)

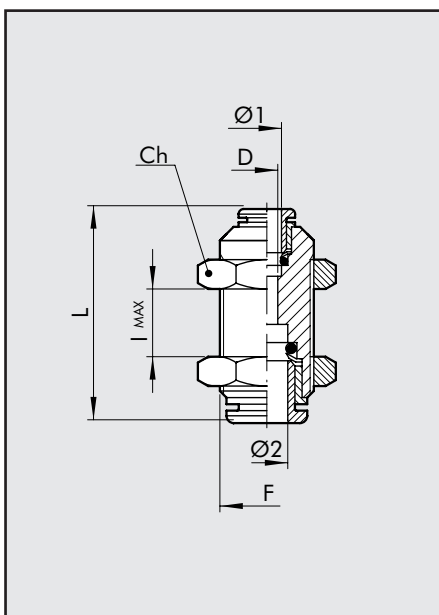

Cód. Ref. Ø1 Ø2 F Ch L D I max

2011A02	R10	3	3	M8x0.75	10	18.4	2	5
2011A01	R10	3.17	3.17	M8x0.75	10	18.4	2	5
2L11001	RL10	4	4	M11x1	13	30.6	2.5	11
2011002	R10	5	5	M14x1	17	33.5	4	8
2L11003	RL10	6	6	M13x1	16	33	4.5	12
2L11004	RL10	8	8	M15x1	17	35.7	6.5	13.5
2L11005	RL10	10	10	M17x1	20	39.2	8	17
2011006	RL10	12	12	M20x1	24	40.7	10	20.3
2011007	RL10	14	14	M24x1	27	45.9	12	21.9
2L11301	RL10	4	6	M13x1	16	32.7	2.5	11
2L11302	RL10	4	8	M15x1	17	34.4	2.5	12
2L11303	RL10	6	8	M15x1	17	35	4.5	13
2L11304	RL10	6	10	M17x1	20	37.5	4.5	14.5
2L11306	RL10	6	12	M20x1	24	39	4.5	16
2L11305	RL10	8	10	M17x1	20	37.8	6.5	15
2L11307	RL10	8	12	M20x1	24	40.1	6	17.5
2L11308	RL10	10	12	M20x1	24	40.8	8	19

BANJO SIMPLE (R13)

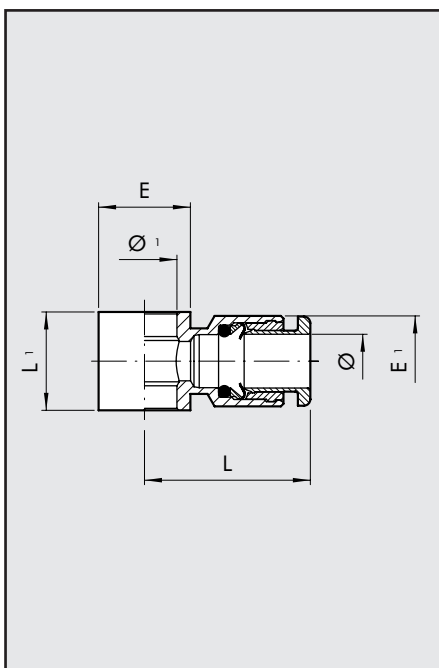

Cód. Ref. Ø Ø1 L L1 E E1

2012A02	R13	3	M5	12.9	9	9	7
2012A01	R13	3.17	M5	12.9	9	9	7
2012001	RL13	4	M5	20.2	9	9.5	9.5
2012002	RL13	4	1/8	21.3	15	14	9.5
2012003	R13	5	M5	23.8	9	9.5	12
2012004	R13	5	1/8	24.8	15	14	12
2012005	RL13	6	1/8	23	15	14	11.5
2012006	RL13	6	1/4	24.5	17	18	11.5
2012007	RL13	8	1/8	24.8	15	14	13.8
2012008	RL13	8	1/4	26.5	17	18	13.8
2012009	RL13	8	3/8	28.5	20	21	13.8
2012010	RL13	10	1/4	31.4	17	18	16.5
2012011	RL13	10	3/8	32.8	20	21	16
2012013	RL13	12	1/4	33	17	18	19.5
2012012	RL13	12	3/8	35.3	20	21	19.5
2012014	RL13	12	1/2	37	24	26	19.5

Para los tornillo Serie D ver pag. 4.1/43



BANJO DOBLE (R14)

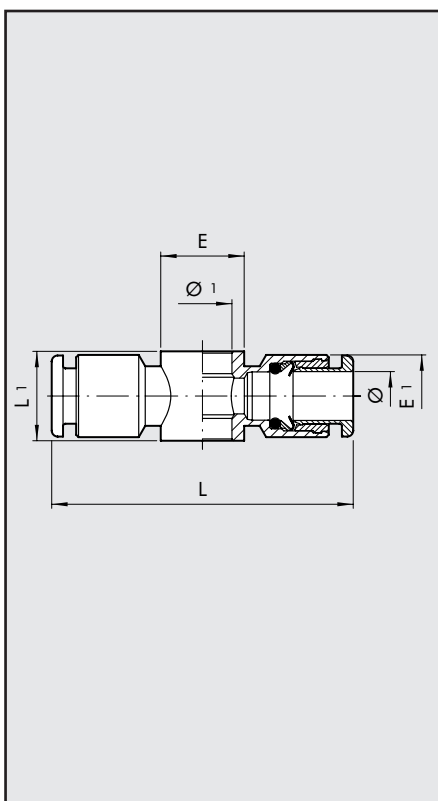

Cód.	Ref.	Ø	Ø 1	L	L1	E	E1
2013001	RL14	4	M5	40.4	9	9.5	9.5
2013002	RL14	4	1/8	42.6	15	14	9.5
2013003	R14	5	M5	48	9	9.5	12
2013004	R14	5	1/8	49.5	15	14	13.5
2013005	RL14	6	1/8	46	15	14	11.5
2013006	RL14	6	1/4	49	17	18	11.5
2013007	RL14	8	1/8	49.6	15	14	13.8
2013008	RL14	8	1/4	53	17	18	13.8
2013009	RL14	8	3/8	57	20	21	13.8
2013010	RL14	10	1/4	62.8	17	18	16.5
2013011	RL14	10	3/8	65.6	20	21	16

For the rods series D, see page 4.1/43

TORNILLO MACHO BANJO SIMPLE GIRATORIO (R15)

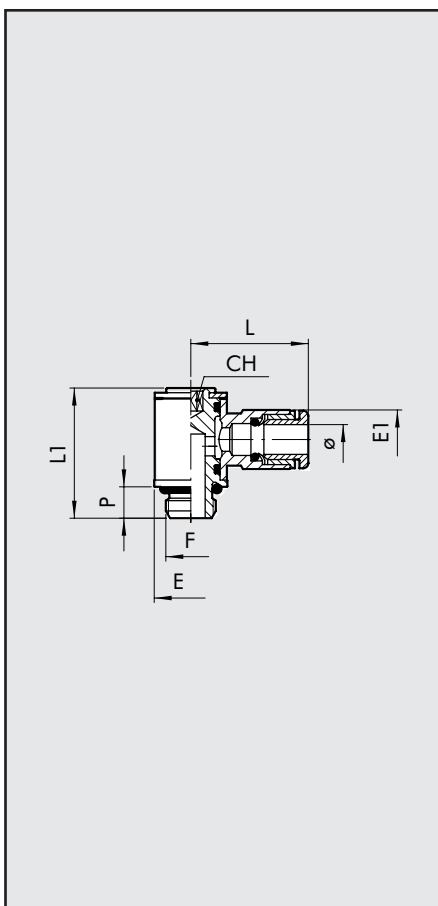

Cód.	Ref.	Ø	F	CH	P	L	L1	E	E1
2014101	R15	3	M3	1.5	3	12.2	13.2	5.8	5.8
2014102	R15	3.17	M3	1.5	3	12.2	13.2	5.8	5.8
2014103	R15	3	M5	2	3.5	12.7	13.7	5.8	7
2014104	R15	3.17	M5	2	3.5	12.7	13.7	5.8	7
2L14001	RL15	4	M5	2	4	20.2	18.4	9.5	9.5
2L14020	RL15	4	M7	3	5	20.2	18.5	9.8	9.5
2L14002	RL15	4	1/8	3	6	21.3	24.9	14	9.5
2014003	R15	5	M5	2	4	24	19	9.9	12
2014004	R15	5	1/8	3	6	25	27	14	12
2L14106	RL15	6	M5	2	4	23.5	18.4	9.5	11.3
2L14021	RL15	6	M7	3	5	23.5	18.5	9.8	11.3
2L14005	RL15	6	1/8	3	6	23	24.9	14	11.5
2L14007	RL15	6	1/4	4	8	24.5	29.4	18	11.5
2L14006	RL15	8	1/8	3	6	24.8	24.9	14	13.8
2L14008	RL15	8	1/4	4	8	26.5	29.4	18	13.8
2L14013	RL15	8	3/8	5	9	28.5	35.6	22	13.8
2L14009	RL15	10	1/4	4	8	31.4	29.4	18	16.5
2L14014	RL15	10	3/8	5	9	32.8	35.6	22	16
2014010	RL15	12	1/4	4	8	33	29.4	18	19.5
2014011	RL15	12	3/8	5	9	35.3	35.6	22	19.5
2014012	RL15	12	1/2	8	11	37	40.8	26	19.5

**TORNILLO MACHO
BANJO DOBLE GIRATORIO (R16)**

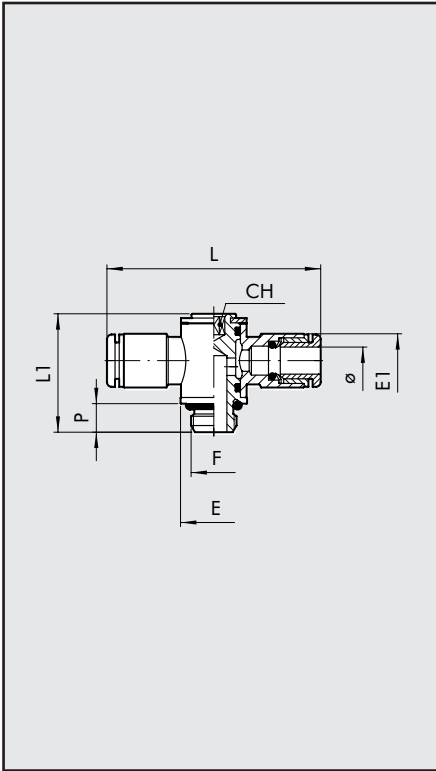

Cód.	Ref.	Ø	F	CH	P	L	L1	E	E1
2L15001	RL16	4	M5	2	4	40.4	18.4	9.5	9.5
2L15020	RL16	4	M7	3	5	40.4	18.5	9.8	9.5
2L15002	RL16	4	1/8	3	6	42.6	24.9	14	9.5
2015003	R16	5	M5	2	4	47.6	18.8	9.9	12
2015004	R16	5	1/8	3	6	49.5	27	14	13.5
2L15106	RL16	6	M5	2	4	47	18.4	9.5	11.3
2L15021	RL16	6	M7	3	5	47	18.5	9.8	11.3
2L15005	RL16	6	1/8	3	6	46	24.9	14	11.5
2L15007	RL16	6	1/4	4	8	49	29.4	18	11.5
2L15006	RL16	8	1/8	3	6	49.6	24.9	14	13.8
2L15008	RL16	8	1/4	4	8	53	29.4	18	13.8
2L15013	RL16	8	3/8	5	9	57	35.6	18	13.8
2L15009	RL16	10	1/4	4	8	62.8	29.4	22	16.5
2L15014	RL16	10	3/8	5	9	65.6	35.6	22	16
2015010	RL16	12	1/4	4	8	66	29.4	18	19.5
2015011	RL16	12	3/8	5	9	70.6	35.6	22	19.5
2015012	RL16	12	1/2	8	11	74	40.8	26	19.5

**L MACHO CILINDRICO
GIRATORIO (R31)**

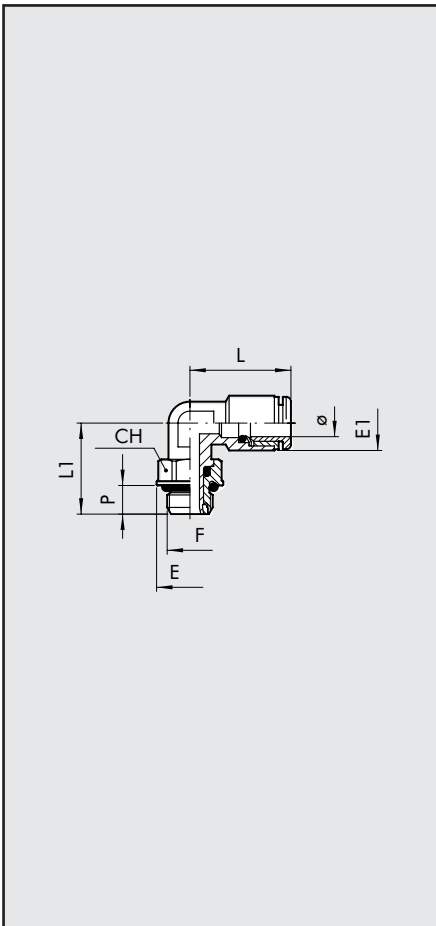

Cód.	Ref.	Ø	F	CH	E	E1	L	L1	P
2L31001	RL31	4	M5	9	9.9	9.5	18.6	15.3	4
2L31002	RL31	4	1/8	12	14	9.5	18.6	19.1	6
2L31003	RL31	4	1/4	14	18	9.5	18.6	21.1	8
2031004	R31	5	M5	9	9.9	13.5	22.8	15.3	4
2031005	R31	5	1/8	12	14	13.5	22.8	19.1	6
2031006	R31	5	1/4	14	18	13.5	22.8	21.8	8
2L31007	RL31	6	M5	9	9.9	11.8	23	15.3	4
2L31008	RL31	6	1/8	12	14	11.8	21.9	19.1	6
2L31009	RL31	6	1/4	14	18	11.8	21.9	21.1	8
2L31010	RL31	8	1/8	12	14	13.5	21.9	19.1	6
2L31011	RL31	8	1/4	14	18	13.5	25.4	21.1	8
2L31012	RL31	8	3/8	17	22	13.8	25.4	27.1	9
2L31013	RL31	10	1/4	14	18	16	23.6	24.8	8
2L31014	RL31	10	3/8	17	22	16	27.2	27.1	9
2031015	RL31	10	1/2	22	26	16	27.2	30.7	11
2031016	RL31	12	1/4	14	18	20	27.2	25.6	8
2031017	RL31	12	3/8	17	22	20	30	27.1	9
2031018	RL31	12	1/2	22	26	20	30	30.7	11
2031019	RL31	14	1/2	22	26	21.3	30	32.3	11



L MACHO CÓNICO GIRATORIO (R31C)

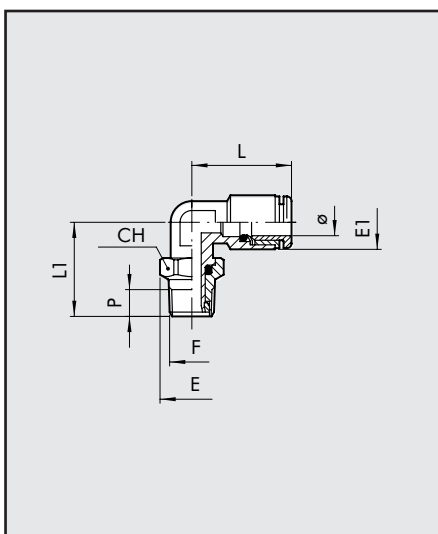

Cód.	Ref.	Ø	F	Ch	E	E1	L	L1	P
2L31C02	RL31/C	4	1/8	12	13.3	9.5	18.6	19.8	6.2
2L31C03	RL31/C	4	1/4	14	15.4	9.5	18.6	22.6	8.5
2L31C08	RL31/C	6	1/8	12	13.3	11.8	21.9	19.8	6.2
2L31C09	RL31/C	6	1/4	14	15.4	11.8	21.9	22.6	8.5
2L31C10	RL31/C	8	1/8	12	13.3	13.5	25.4	19.8	6.2
2L31C11	RL31/C	8	1/4	14	15.4	13.5	25.4	23.6	8.5
2L31C12	RL31/C	8	3/8	17	19.2	13.8	23.6	27.1	9
2L31C13	RL31/C	10	1/4	14	15.4	16	27.2	26.3	8.5
2L31C14	RL31/C	10	3/8	17	19.2	16	27.2	27.1	9
2031C15	RL31/C	12	3/8	17	19.2	20	30	27.1	9
2031C16	RL31/C	12	1/2	22	24.6	20	30	31.9	11

T CENTRAL MACHO CILINDRICO GIRATORIO (R32)

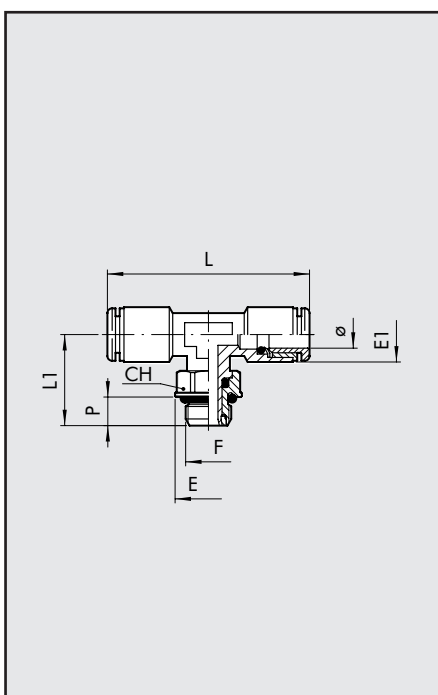

Cód.	Ref.	Ø	F	CH	E	E1	L	L1	P
2L32001	RL32	4	M5	9	9.9	9.5	37.2	15.3	4
2L32002	RL32	4	1/8	12	14	9.5	37.2	19.1	6
2L32003	RL32	4	1/4	14	18	9.5	37.2	21.1	8
2L32005	R32	5	1/8	12	14	13.5	45.6	19.1	6
2L32004	RL32	6	M5	9	9.9	11.8	43.8	15.3	4
2L32008	RL32	6	1/8	12	14	11.8	43.8	19.1	6
2L32009	RL32	6	1/4	14	18	11.8	43.8	21.1	8
2L32010	RL32	8	1/8	12	14	13.5	50.8	19.1	6
2L32011	RL32	8	1/4	14	18	13.5	50.8	21.1	8
2L32012	RL32	8	3/8	17	22	13.8	47.2	27.1	9
2L32013	RL32	10	1/4	14	18	16	44.4	21.8	8
2L32014	RL32	10	3/8	17	22	16	44.4	27.1	9
2032017	RL32	12	3/8	17	22	20	60	27.1	9
2032018	RL32	12	1/2	22	26	20	60	30.7	11
2032019	RL32	14	1/2	22	26	21.3	66	32.3	11

T CENTRAL MACHO CÓNICO GIRATORIO (R32C)

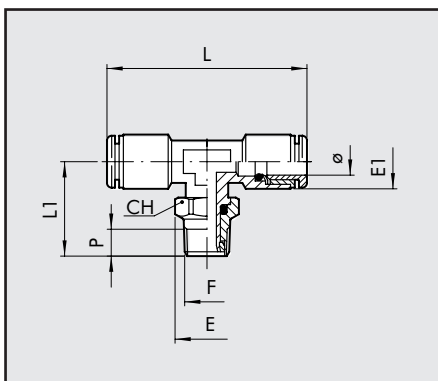

Cód.	Ref.	Ø	F	CH	E	E1	L	L1	P
2L32C02	RL32/C	4	1/8	12	13.3	9.5	37.2	19.8	6.2
2L32C03	RL32/C	4	1/4	14	15.4	9.5	37.2	22.6	8.5
2L32C08	RL32/C	6	1/8	12	13.3	11.8	43.8	19.8	6.2
2L32C09	RL32/C	6	1/4	14	15.4	11.8	43.8	22.6	8.5
2L32C10	RL32/C	8	1/8	12	13.3	13.5	50.8	19.8	6.2
2L32C11	RL32/C	8	1/4	14	15.4	13.5	50.8	23.6	8.5
2L32C12	RL32/C	8	3/8	17	19.2	13.8	47.2	27.1	9
2L32C13	RL32/C	10	1/4	14	15.4	16	44.4	26.3	8.5
2L32C14	RL32/C	10	3/8	17	19.2	16	44.4	27.1	9

T LATERAL MACHO CILÍNDRICO GIRATORIO (R38)

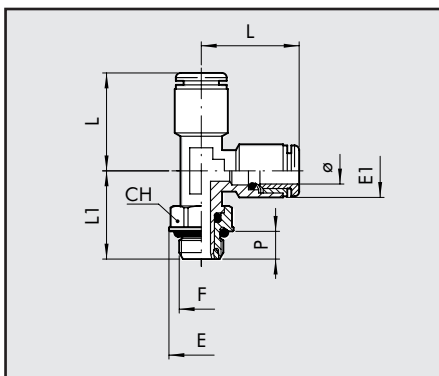

Cód.	Ref.	Ø	F	Ch	E	E1	L	L1	P
2L38002	RL38	4	1/8	12	14	9.5	18.6	19.1	6
2038005	R38	5	1/8	12	14	13.5	22.8	19.1	6
2L38008	RL38	6	1/8	12	14	11.5	21.9	19.1	6
2L38009	RL38	6	1/4	14	18	11.5	21.9	21.1	8
2L38010	RL38	8	1/8	12	14	13.5	25.4	19.1	6
2L38011	RL38	8	1/4	14	18	13.5	25.4	22.1	8
2L38013	RL38	10	1/4	14	18	16	27.2	21.8	8
2L38014	RL38	10	3/8	17	22	16	27.2	27.1	9
2038015	RL38	12	3/8	17	22	20	30	27.1	9
2038016	RL38	12	1/2	22	26	20	30	30.7	11

L MACHO CÓNICO (R39C)

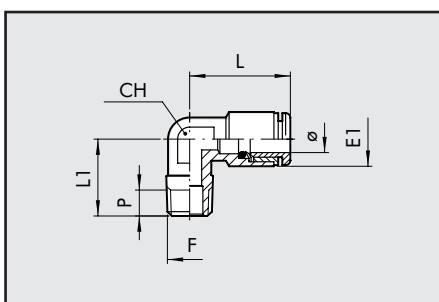

Cód.	Ref.	Ø	F	CH	E1	L	L1	P
2L39C02	RL39/C	4	1/8	10	9.5	18.6	16	6.2
2L39C08	RL39/C	6	1/8	10	11.8	21.9	16	6.2
2L39C09	RL39/C	6	1/4	10	11.8	21.9	18.5	8.5
2039Z07	RL39/Z	6	12x1 con.	10	11.8	21.9	17.5	7
2039Z08	RL39/Z	6	12x1.25 con.	10	11.8	21.9	17.5	7
2L39C10	RL39/C	8	1/8	10	13.5	25.4	16	6.2
2L39C11	RL39/C	8	1/4	10	13.5	25.4	18.5	8.5
2L39C13	RL39/C	10	1/4	14	16	27.2	22	8.5

CRUZ (RL40)

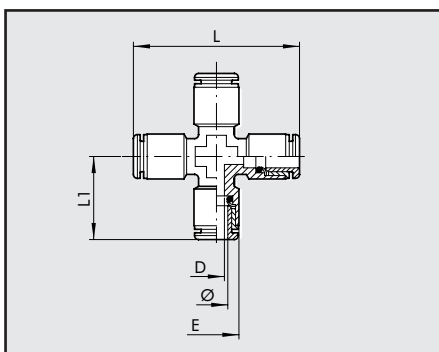

Cód.	Ref.	Ø	D	E	L	L1
2L40001	RL40	4	3	9.5	37.2	18.6
2L40003	RL40	6	4.5	11.3	43.8	21.9
2L40004	RL40	8	6.5	14	50.8	25.4

TORNILLO DOBLE BANJO SIMPLE GIRATORIO (R50)

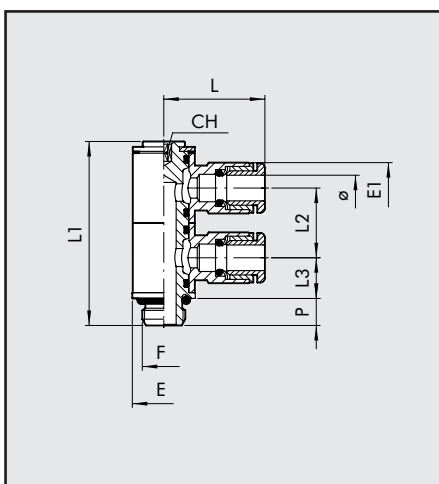

Cód.	Ref.	Ø	F	CH	E	E1	L	L1	L2	L3	P
2L50001	RL50	4	M5	2	9.5	9.5	20.2	30.3	11.5	6.8	4
2L50002	RL50	4	1/8	3	14	9.5	20.2	40.9	15.5	9.1	6
2033002	R33	5	1/8	5	14	12	25	42	15	10.5	6
2L50007	RL50	6	M5	2	9.5	11.3	23.5	30.3	11.5	6.8	4
2L50008	RL50	6	1/8	3	14	11.3	23.5	40.9	15.5	9.1	6
2L50009	RL50	6	1/4	4	18	11.5	23	47	17.2	10.2	8
2L50010	RL50	8	1/8	3	14	13.8	24.8	40.9	15.5	9.1	6
2L50011	RL50	8	1/4	4	18	13.8	26.5	47	17.2	10.2	8
2L50013	RL50	10	1/4	4	18	16.5	31.4	47	17.2	10.2	8



**TORNILLO DOBLE
BANJO DOBLE GIRATORIO (RL51)**

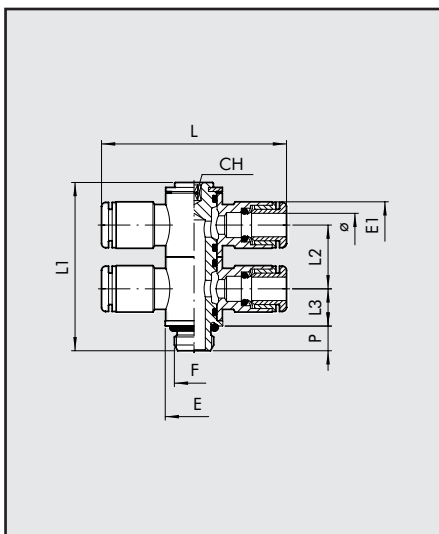

Cód.	Ref.	Ø	F	Ch	E	E1	L	L1	L2	L3	P
2L51001	RL51	4	M5	2	9.5	9.5	40.4	30.3	11.5	6.8	4
2L51002	RL51	4	1/8	3	14	9.5	40.4	40.9	15.5	9.1	6
2L51007	RL51	6	M5	2	9.5	11.3	47	30.3	11.5	6.8	4
2L51008	RL51	6	1/8	3	14	11.3	47	40.9	15.5	9.1	6
2L51009	RL51	6	1/4	4	18	11.5	46	47	17.2	10.2	8
2L51010	RL51	8	1/8	3	14	13.8	49.6	40.9	15.5	9.1	6
2L51011	RL51	8	1/4	4	18	13.8	53	47	17.2	10.2	8
2L51013	RL51	10	1/4	4	18	16.5	62.8	47	17.2	10.2	8

**TORNILLO TRIPLE
BANJO SIMPLE GIRATORIO (RL52)**

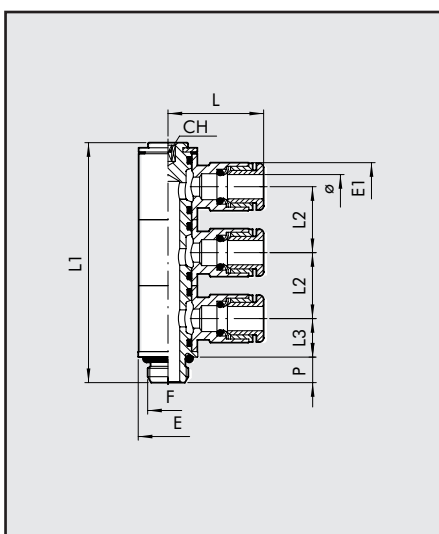

Cód.	Ref.	Ø	F	Ch	E	E1	L	L1	L2	L3	P
2L52002	RL52	4	1/8	3	14	9.5	20.2	56.7	15.5	9.1	6
2L52008	RL52	6	1/8	3	14	11.3	23.5	56.7	15.5	9.1	6
2L52009	RL52	6	1/4	4	18	11.5	23	64.3	17.2	10.2	8
2L52010	RL52	8	1/8	3	14	13.8	24.8	56.7	15.5	9.1	6
2L52011	RL52	8	1/4	4	18	13.8	26.5	64.3	17.2	10.2	8
2L52013	RL52	10	1/4	4	18	16.5	31.4	64.3	17.2	10.2	8

**TORNILLO TRIPLE
BANJO DOBLE GIRATORIO (RL53)**

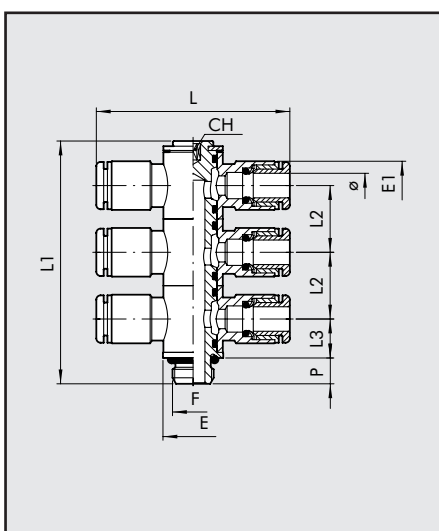

Cód.	Ref.	Ø	F	Ch	E	E1	L	L1	L2	L3	P
2L53002	RL53	4	1/8	3	14	9.5	40.2	56.7	15.5	9.1	6
2L53008	RL53	6	1/8	3	14	11.3	47	56.7	15.5	9.1	6
2L53009	RL53	6	1/4	4	18	11.5	46	64.3	17.2	10.2	8
2L53010	RL53	8	1/8	3	14	13.8	49.6	56.7	15.5	9.1	6
2L53011	RL53	8	1/4	4	18	13.8	53	64.3	17.2	10.2	8
2L53013	RL53	10	1/4	4	18	16.5	62.8	64.3	17.2	10.2	8

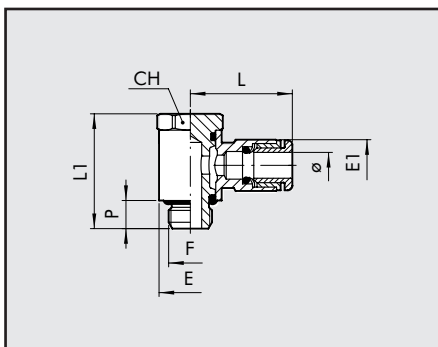
**TORNILLO MACHO
BANJO SIMPLE ORIENTABLE (RL54)**

Cód.	Ref.	Ø	F	Ch	E	E1	L	L1	P
2L54001	RL54	4	M5	9	9.5	9.5	20.2	18.7	4.5
2L54002	RL54	4	1/8	13	14	9.5	21.3	25.3	6.2
2L54007	RL54	6	M5	9	9.5	11.3	23.5	18.7	4.5
2L54008	RL54	6	1/8	13	14	11.5	23	25.3	6.2
2L54009	RL54	6	1/4	16	18	11.5	24.5	29.2	8
2L54010	RL54	8	1/8	13	14	13.8	24.8	25.3	6.2
2L54011	RL54	8	1/4	16	18	13.8	26.5	29.2	8
2L54012	RL54	8	3/8	20	21	13.8	28.5	35.4	9
2L54013	RL54	10	1/4	16	18	16.5	31.4	29.2	8
2L54014	RL54	10	3/8	20	21	16	32.8	35.4	9
2L54018	RL54	12	1/4	16	18	19.5	33	29.2	8
2L54016	RL54	12	3/8	20	21	19.5	35.3	35.4	9
2L54017	RL54	12	1/2	25	26	19.5	37	40	11

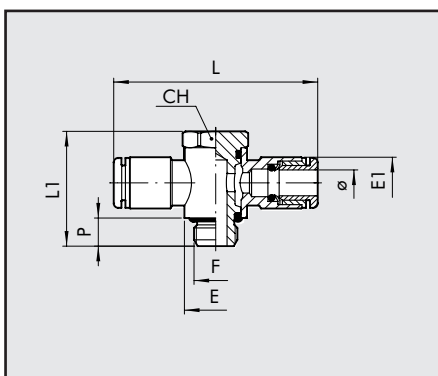
**TORNILLO MACHO
BANJO DOBLE ORIENTABLE (RL55)**

Cód.	Ref.	Ø	F	Ch	E	E1	L	L1	P
2L55001	RL55	4	M5	9	9.5	9.5	40.4	18.7	4.5
2L55002	RL55	4	1/8	13	14	9.5	42.6	25.3	6
2L55007	RL55	6	M5	9	9.5	11.3	47	18.7	4.5
2L55008	RL55	6	1/8	13	14	11.5	46	25.3	6
2L55009	RL55	6	1/4	16	18	11.5	49	29.2	8
2L55010	RL55	8	1/8	13	14	13.8	49.6	25.3	6
2L55011	RL55	8	1/4	16	18	13.8	53	29.2	8
2L55012	RL55	8	3/8	20	21	13.8	57	35.4	9
2L55013	RL55	10	1/4	16	18	16.5	62.8	29.2	8
2L55014	RL55	10	3/8	20	21	16	65.6	35.4	9
2L55018	RL55	12	1/4	16	18	19.5	66	29.2	8
2L55016	RL55	12	3/8	20	21	19.5	70.6	35.4	9
2L55017	RL55	12	1/2	25	26	19.5	74	40	11

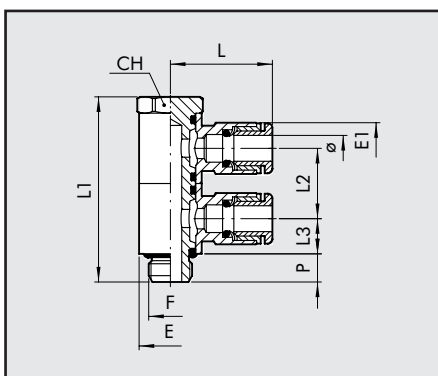
**TORNILLO DOBLE MACHO
BANJO SIMPLE ORIENTABLE (RL56)**

Cód.	Ref.	Ø	F	Ch	E	E1	L	L1	L2	L3	P
2L56001	RL56	4	M5	9	9.5	9.5	20.2	30.2	11.5	5.8	4.5
2L56002	RL56	4	1/8	13	14	9.5	21.3	41	15.5	7.8	6
2L56007	RL56	6	M5	9	9.5	11.3	23.5	30.2	11.5	5.8	4.5
2L56008	RL56	6	1/8	13	14	11.5	23	41	15.5	7.8	6
2L56009	RL56	6	1/4	16	18	11.5	24.5	46.4	17.2	8.6	8
2L56010	RL56	8	1/8	13	14	13.8	24.8	41	15.5	7.8	6
2L56011	RL56	8	1/4	16	18	13.8	26.5	46.4	17.2	8.6	8
2L56012	RL56	8	3/8	20	21	13.8	28.5	56.8	21.4	10.7	9
2L56013	RL56	10	1/4	16	18	16.5	31.4	46.4	17.2	8.6	8
2L56014	RL56	10	3/8	20	21	16	32.8	56.8	21.4	10.7	9
2L56016	RL56	12	3/8	20	21	19.5	35.3	56.8	21.4	10.7	9
2L56017	RL56	12	1/2	25	26	19.5	37	64	24	12	11

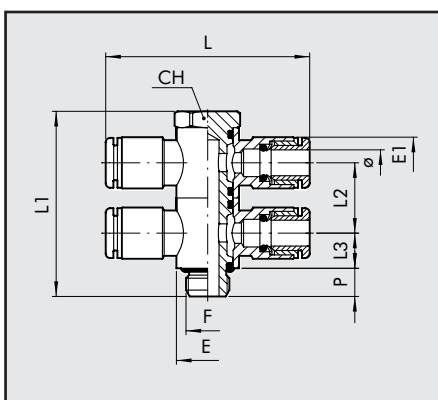
**TORNILLO DOBLE MACHO
BANJO DOBLE ORIENTABLE (RL57)**

Cód.	Ref.	Ø	F	Ch	E	E1	L	L1	L2	L3	P
2L57001	RL57	4	M5	9	9.5	9.5	40.4	30.2	11.5	5.8	4.5
2L57002	RL57	4	1/8	13	14	9.5	42.6	41	15.5	7.8	6
2L57007	RL57	6	M5	9	9.5	11.3	47	30.2	11.5	5.8	4.5
2L57008	RL57	6	1/8	13	14	11.5	46	41	15.5	7.8	6
2L57009	RL57	6	1/4	16	18	11.5	49	46.4	17.2	8.6	8
2L57010	RL57	8	1/8	13	14	13.8	49.6	41	15.5	7.8	6
2L57011	RL57	8	1/4	16	18	13.8	53	46.4	17.2	8.6	8
2L57012	RL57	8	3/8	20	21	13.8	57	56.8	21.4	10.7	9
2L57013	RL57	10	1/4	16	18	16.5	62.8	46.4	17.2	8.6	8
2L57014	RL57	10	3/8	20	21	16	65.6	56.8	21.4	10.7	9
2L57016	RL57	12	3/8	20	21	19.5	70.6	56.8	21.4	10.7	9
2L57017	RL57	12	1/2	25	26	19.5	74	64	24	12	11



RACORES EN TECNOPOLIMERO

RECTO INTERMEDIO TECNOPOLIMERO (R19)

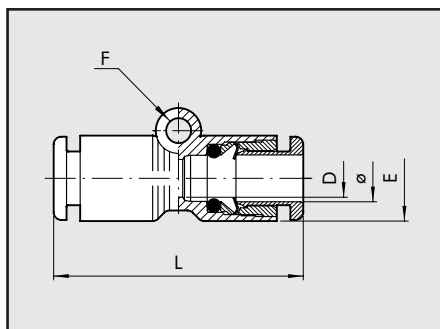

Cód.	Ref.	Ø	E	L	D	F
2019001	RL19	4	9.2	30.4	3	3.3
2019002	R19	5	14	33.5	4	-
2019003	RL19	6	11.3	33	5	3.3
2019004	RL19	8	13.8	36.2	6.5	3.3
2019005	RL19	10	16	38	8.5	3.3
2019006	RL19	12	19.5	40	10.5	3.3

TORNILLO MACHO BANJO SIMPLE GIRATORIO TECNOPOLIMERO (R20)

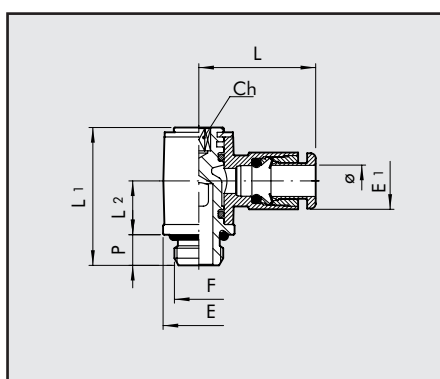

Cód.	Ref.	Ø	F	Ch	P	L	L1	L2	E	E1
2020001	RL20	4	M5	2	4	18.7	18.4	9.1	8	9.2
2020002	RL20	4	1/8	3	6	21	24.9	12.3	14	9.2
2020003	R20	5	M5	2	4	21.5	18.8	8.5	9.9	13.5
2020004	R20	5	1/8	3	6	23	27	10.5	14	13.5
2020016	RL20	6	M5	2	4	20.8	18.4	9.1	8	11.3
2020005	RL20	6	1/8	3	6	22.3	24.9	12.3	14	11.3
2020007	RL20	6	1/4	4	8	24.3	29.4	14.3	18	11.3
2020006	RL20	8	1/8	3	6	25.6	24.9	12.3	14	13.8
2020008	RL20	8	1/4	4	8	27.2	29.4	14.3	18	13.8
2020009	RL20	10	1/4	4	8	28.6	29.4	14.3	18	16
2L20017	RL20	10	3/8	5	9	30.5	35.6	15.3	22	16
2020010	RL20	12	1/4	4	8	31	29.4	14.3	18	19.5
2020011	RL20	12	3/8	5	9	32.4	35.6	17.5	22	19.5
2020012	RL20	12	1/2	8	11	34	40.8	19.2	26	19.5

TORNILLO MACHO BANJO DOBLE GIRATORIO TECNOPOLIMERO (R20/A)

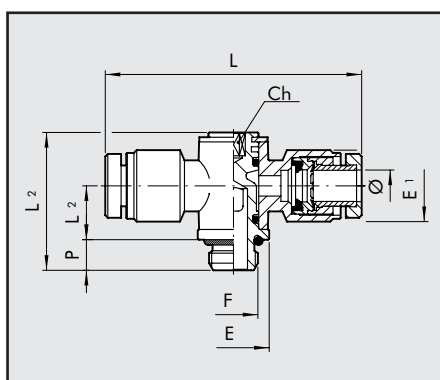

Cód.	Ref.	Ø	F	Ch	P	L	L1	L2	E	E1
2020A01	R20/A	4	M5	2	4	40	16.8	6.5	9.9	10.9
2020A02	R20/A	4	1/8	3	6	45	27	10.5	14	12.5
2020A03	R20/A	5	M5	2	4	43	18.8	8.5	9.9	13.5
2020A04	R20/A	5	1/8	3	6	46	27	10.5	14	13.5
2020A05	R20/A	6	1/8	3	6	45	27	10.5	14	15
2020A07	R20/A	6	1/4	4	8	48	31.5	11.5	18	15
2020A06	R20/A	8	1/8	3	6	51	27	10.5	14	16.3
2020A08	R20/A	8	1/4	4	8	54	31.5	11.5	18	16.3
2020A09	R20/A	10	1/4	4	8	64	31.5	11.5	18	18.5
2020A10	R20/A	12	1/4	4	8	64	31.5	11.5	18	21
2020A11	R20/A	12	3/8	5	9	68	36	13.5	22	21
2020A12	R20/A	12	1/2	8	11	72	42	16.2	26	21

L INTERMEDIO TECNOPOLIMERO (R21)

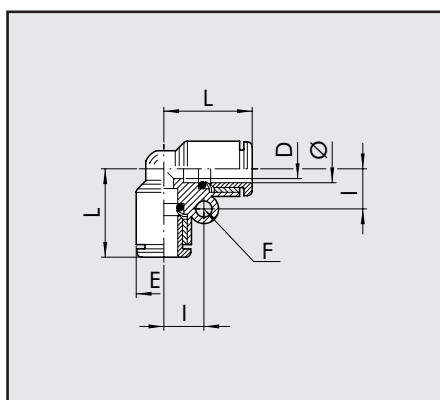

Cód.	Ref.	Ø	L	D	E	I	F
2L21001	RL21	4	16.7	2.5	9.2	7.2	3.3
2021002	R21	5	20	3.5	13.5	-	-
2L21003	RL21	6	19	4.2	11.3	8.2	3.3
2L21004	RL21	8	21.4	6.2	13.8	9.6	3.3
2021005	RL21	10	24	8.5	16	10.9	3.3
2021006	RL21	12	25.8	10.5	19.5	12.5	3.3

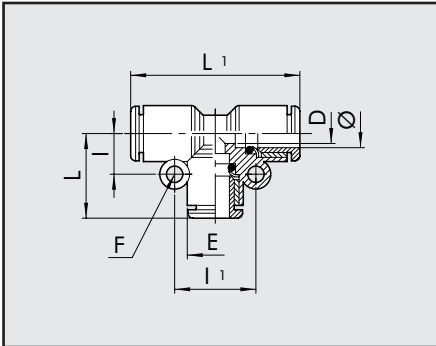
**T INTERMEDIO
TECNOPOLIMERO (R22)**

Cód.	Ref.	Ø	L	L1	D	E	I	I1	F
2L22001	RL22	4	16.7	33.4	2.5	9.2	7.2	14.4	3.3
2022002	R22	5	20	40	3.5	13.5	-	-	-
2L22003	RL22	6	19	38	4.2	11.3	8.2	16.4	3.3
2L22004	RL22	8	21.4	42.8	6.2	13.8	9.6	19.2	3.3
2022005	RL22	10	24	48	8.5	16	10.9	21.8	3.3
2022006	RL22	12	25.8	51.6	10.5	19.5	12.5	25	3.3

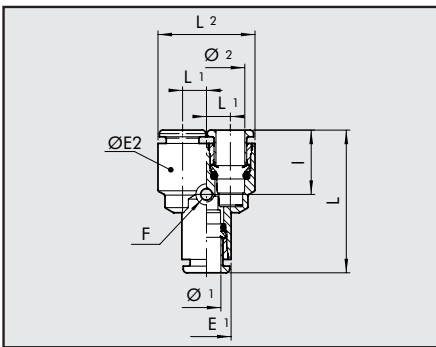
Y TECNOPOLIMERO (R23)

Cód.	Ref.	Ø1	Ø2	L	L1	E1	Ø2	I	F
2023001	RL23	4	4	32.9	5	9.2	9.2	14.8	3.3
2023002	R23	5	5	35.5	6.5	13.5	13.5	-	-
2023003	RL23	6	6	35.5	5.8	11.3	11.3	15	3.3
2023004	RL23	8	8	39.5	7.2	13.8	13.8	15.8	3.3
2L23005	RL23	10	10	43.1	8.3	16	16	17.4	3.3
2L23006	RL23	12	12	48	10	19.5	19.5	18	3.3
2L23301	RL23	6	4	34.2	5	11.3	9.2	14.8	3.3
2L23303	RL23	8	6	37.8	5.8	13.8	11.3	15	3.3
2L23306	RL23	10	8	40.4	7.2	16	13.8	15.8	3.3
2L23309	RL23	12	10	44.2	8.3	19.5	16	17.4	3.3

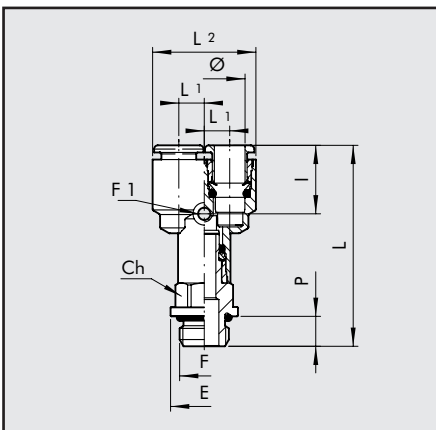
Y TECNOPOLIMERO (RL23/M)

Cód.	Ref.	Ø	F	L	L1	L2	I	Ch	P	E	F1
2L23401	RL23/M	4	M5	38.7	5	19.2	14.8	9	4	9.9	3.3
2L23402	RL23/M	4	1/8	42.6	5	19.2	14.8	12	6	14	3.3
2L23403	RL23/M	4	1/4	46.6	5	19.2	14.8	14	8	18	3.3
2L23406	RL23/M	6	1/8	44.9	5.75	22.8	15	12	6	14	3.3
2L23407	RL23/M	6	1/4	47.9	5.75	22.8	15	14	8	18	3.3
2L23409	RL23/M	8	1/8	48.4	7.2	28.2	15.8	14	6	15	3.3
2L23410	RL23/M	8	1/4	52.8	7.2	28.2	15.8	14	8	18	3.3
2L23412	RL23/M	8	3/8	54.4	7.2	28.2	15.8	17	9	22	3.3
2L23413	RL23/M	10	1/4	53.8	8.3	32.6	17.4	16	8	18	3.3
2L23415	RL23/M	10	3/8	56	8.3	32.6	17.4	17	9	20	3.3
2L23419	RL23/M	12	3/8	62	10	39.5	18	19	9	22	3.3
2L23420	RL23/M	12	1/2	62.3	10	39.5	18	22	11	26	3.3

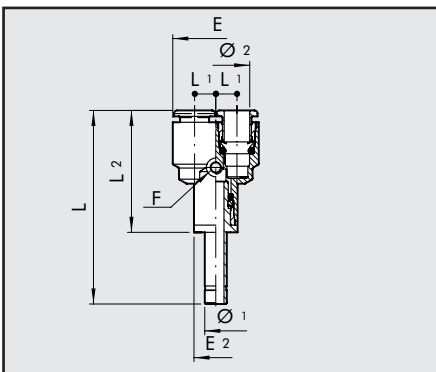
**Y CON ADAPTADOR
TECNOPOLIMERO (R24)**

Cód.	Ref.	Ø1	Ø2	L	L1	L2	E1	E2	I	F
2024001	RL24	4	4	46.9	5	29.7	9.2	9.2	14.8	3.3
2024003	RL24	6	6	49.7	5.75	32	11.3	11.3	15	3.3
2L24004	RL24	8	8	55.1	7.2	35.9	13.8	13.8	15.8	3.3
2L24005	RL24	10	10	63.1	8.3	39.2	16	16	17.4	3.3
2L24006	RL24	12	12	70.5	10	44	19.5	19.5	18	3.3
2L24301	RL24	6	4	48.4	5	30.7	9.2	11.3	14.8	3.3
2L24303	RL24	8	6	53.4	5.75	34.2	11.3	13.8	15	3.3
2L24306	RL24	10	8	60.4	7.2	36.6	13.8	16	15.8	3.3
2L24309	RL24	12	10	66.7	8.3	40.2	16	19.5	17.4	3.3



BANJO GIRATORIO TECNOPOLIMERO DOBLE PARALELO (RL25)

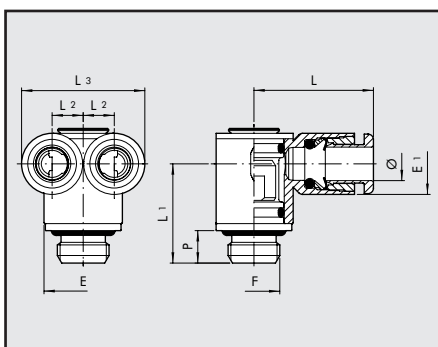

Cód.	Ref.	Ø	F	L	L1	L2	L3	E	E1	Ch	P
2L25001	RL25	4	M5	17.7	13.1	5	19.2	8	9.2	2	4
2L25002	RL25	4	M7	17.7	14.6	5	19.2	9.8	9.2	3	5
2L25003	RL25	4	1/8	17.7	16.5	5	19.2	13	9.2	3	6
2L25004	RL25	6	1/8	23	18.3	5.75	22.8	14	11.3	3	6
2L25005	RL25	6	1/4	23	21.2	5.75	22.8	16.4	11.3	4	8
2L25008	RL25	8	1/4	25.8	22.2	7.2	28.2	18	13.8	4	8
2L25009	RL25	8	3/8	25.8	23.8	7.2	28.2	20	13.8	5	9

BANJO SIMPLE TECNOPOLIMERO (R28)

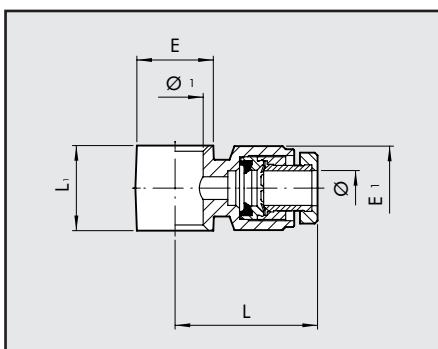

Cód.	Ref.	Ø	Ø1	L	L1	E	E1
2012102	R28	4	1/8	22.5	17	15	12.5
2012104	R28	5	1/8	23	17	15	13.5
2012106	R28	6	1/8	22.5	17	15	15
2012107	R28	6	1/4	24	19	18	15
2012108	R28	8	1/8	25.5	17	15	16.5
2012109	R28	8	1/4	27	19	18	16.5
2012110	R28	8	3/8	29	22	21.5	16.5
2012111	R28	10	1/4	32	19	18	18.5
2012112	R28	10	3/8	32	22	21.5	18.5
2012113	R28	12	1/4	32	19	18	21
2012114	R28	12	3/8	34	22	21.5	21
2012115	R28	12	1/2	36	24	26	21

Para los tornillos Serie D ver pag. 4.1/43

BANJO DOBLE TECNOPOLIMERO (R29)

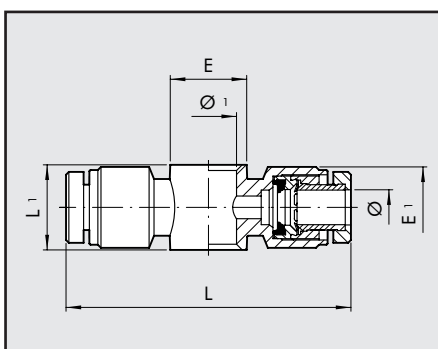

Cód.	Ref.	Ø	Ø1	L	L1	E	E1
2013102	R29	4	1/8	45	17	15	12.5
2013104	R29	5	1/8	46	17	15	13.5
2013106	R29	6	1/8	45	17	15	15
2013107	R29	6	1/4	48	19	18	15
2013108	R29	8	1/8	51	17	15	16.5
2013109	R29	8	1/4	54	19	18	16.5
2013110	R29	8	3/8	58	22	21.5	16.5
2013111	R29	10	1/4	64	19	18	18.5
2013112	R29	10	3/8	64	22	21.5	18.5
2013113	R29	12	1/4	64	19	18	21
2013114	R29	12	3/8	68	22	21.5	21
2013115	R29	12	1/2	72	24	26	21

Para los tornillos Serie D ver pag. 4.1/43

L MACHO GIRATORIA TECNOPOLIMERO (RL34)

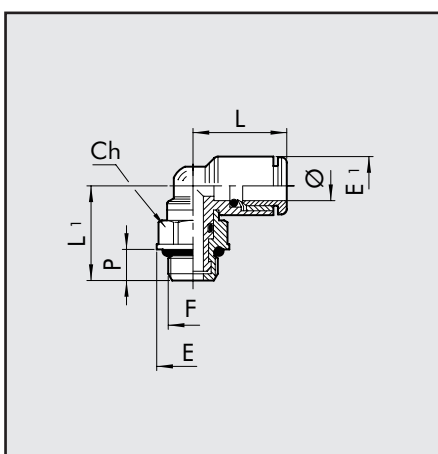

Cód.	Ref.	Ø	F	Ch	P	L	L1	E	E1
2L34001	RL34	4	M5	8	4	16.4	15.2	9	9.2
2L34020	RL34	4	M7	8	5	16.4	16.2	9.8	9.2
2L34002	RL34	4	1/8	12	6	16.4	17.2	14	9.2
2L34003	RL34	4	1/4	14	8	16.4	20.1	18	9.2
2L34006	RL34	6	M5	8	4	18	16.3	9	11.3
2L34021	RL34	6	M7	9	5	19	17.5	9.9	11.3
2L34007	RL34	6	1/8	12	6	19	18.3	14	11.3
2L34008	RL34	6	1/4	14	8	19	21.2	18	11.3
2L34009	RL34	8	1/8	12	6	20.2	19.5	14	13.8
2L34010	RL34	8	1/4	14	8	20.2	22.4	18	13.8
2L34011	RL34	8	3/8	17	9	20.2	24.4	22	13.8
2L34013	RL34	10	1/4	14	8	23.3	23.5	18	16
2L34014	RL34	10	3/8	17	9	23.3	25.6	22	16
2L34016	RL34	12	3/8	17	9	25.2	27.3	22	19.5
2L34017	RL34	12	1/2	19	11	25.2	30.3	26	19.5

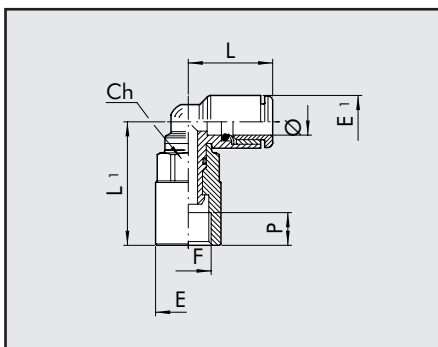
**L HEMBRA GIRATORIA
TECNOPLIMERO (RL34/F)**

Cod.	Ref.	Ø	F	CH	E	E1	L	L1	P
2L34F01	RL34/F	4	M5	8	9	9.2	16.4	15.3	4
2L34F05	RL34/F	4	1/8	12	14	9.2	16.4	20.9	7
2L34F06	RL34/F	6	M5	8	9	11.3	18	16.4	4
2L34F07	RL34/F	6	1/8	12	14	11.3	19	26.5	7
2L34F08	RL34/F	6	1/4	14	17	11.3	19	28.2	8
2L34F09	RL34/F	8	1/8	12	14	13.8	20.2	27.7	7
2L34F10	RL34/F	8	1/4	14	17	13.8	20.2	29.4	8
2L34F13	RL34/F	10	1/4	14	17	16	23.3	33	8
2L34F14	RL34/F	10	3/8	17	21	16	23.3	38	10
2L34F16	RL34/F	12	3/8	17	21	19.5	25.2	40.3	10
2L34F17	RL34/F	12	1/2	19	23.8	19.5	25.2	42.8	11

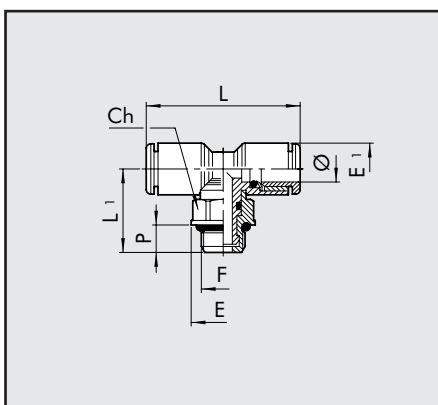
**T CENTRAL MACHO
TECNOPLIMERO (RL35)**

Cod.	Ref.	Ø	F	Ch	P	L	L1	E	E1
2L35001	RL35	4	M5	8	4	31	32.8	9	9.2
2L35020	RL35	4	M7	8	5	31	32.8	9.8	9.2
2L35002	RL35	4	1/8	12	6	31	32.8	14	9.2
2L35003	RL35	4	1/4	14	8	31	32.8	18	9.2
2L35006	RL35	6	M5	8	4	34.2	36	9	11.3
2L35007	RL35	6	1/8	12	6	36.2	38	14	11.3
2L35008	RL35	6	1/4	14	8	36.2	38	18	11.3
2L35009	RL35	8	1/8	12	6	38.6	40.4	14	13.8
2L35010	RL35	8	1/4	14	8	38.6	40.4	18	13.8
2L35011	RL35	8	3/8	17	9	38.6	40.4	22	13.8
2L35013	RL35	10	1/4	14	8	46.6	23.5	18	16
2L35014	RL35	10	3/8	17	9	46.6	25.6	22	16
2L35016	RL35	12	3/8	17	9	50.4	27.3	22	19.5
2L35017	RL35	12	1/2	19	11	50.4	30.3	26	19.5

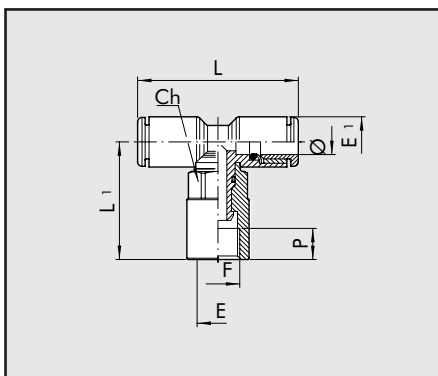
**T CENTRAL HEMBRA GIRATORIA
TECNOPLIMERO (RL35/F)**

Cod.	Ref.	Ø	F	CH	E	E1	L	L1	P
2L35F01	RL35/F	4	M5	8	9	9.2	32.8	15.3	4
2L35F06	RL35/F	6	M5	8	9	11.3	36	16.4	4
2L35F07	RL35/F	6	1/8	12	14	11.3	38	26.5	7
2L35F08	RL35/F	6	1/4	14	17	11.3	38	28.2	8
2L35F09	RL35/F	8	1/8	12	14	13.8	40.4	27.7	7
2L35F10	RL35/F	8	1/4	14	17	13.8	40.4	29.4	8
2L35F13	RL35/F	10	1/4	14	17	16	46.6	33	8
2L35F14	RL35/F	10	3/8	17	21	16	46.6	38	10
2L35F16	RL35/F	12	3/8	17	21	19.5	50.4	40.3	10
2L35F17	RL35/F	12	1/2	19	23.8	19.5	50.4	42.8	11

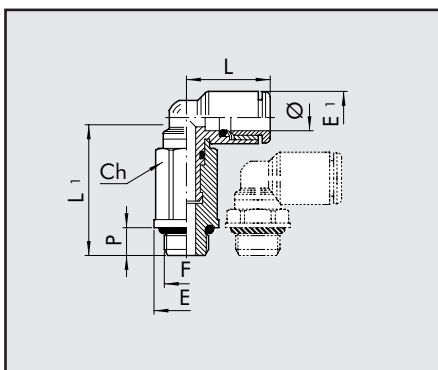
**L MACHO GIRATORIA PROLONGADA
TECNOPLIMERO (RL36)**

Cod.	Ref.	Ø	F	Ch	P	L	L1	E	E1
2L36001	RL36	4	M5	8	4	16.4	26.7	9	9.2
2L36020	RL36	4	M7	8	5	16.4	27.7	9.8	9.2
2L36002	RL36	4	1/8	12	6	16.4	25.3	14	9.2
2L36006	RL36	6	M5	8	4	18	27.8	9	11.3
2L36021	RL36	6	M7	9	5	18	29.3	9.9	11.3
2L36007	RL36	6	1/8	12	6	19	30.9	14	11.3
2L36008	RL36	6	1/4	14	8	19	33.2	18	11.3
2L36009	RL36	8	1/8	12	6	20.2	32.1	14	13.8
2L36010	RL36	8	1/4	14	8	20.2	34.4	18	13.8
2L36012	RL36	10	1/4	14	8	23.3	38	18	16



T CENTRAL MACHO GIRATORIA TECNOPLIMERO (RL37)

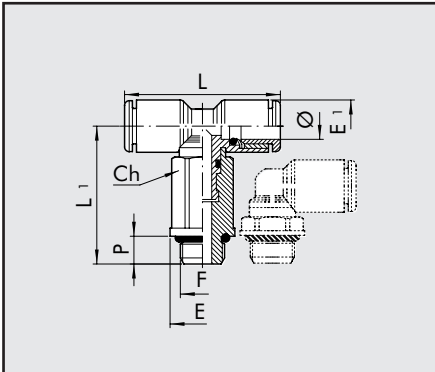

Cod.	Ref.	Ø	F	Ch	P	L	L1	E	E1
2L37001	RL37	4	M5	8	4	32.8	26.7	9	9.2
2L37020	RL37	4	M7	8	5	32.8	27.5	9.8	9.2
2L37002	RL37	4	1/8	12	6	32.8	25.3	14	9.2
2L37006	RL37	6	M5	8	4	36	27.8	9	11.3
2L37007	RL37	6	1/8	12	6	38	30.9	14	11.3
2L37008	RL37	6	1/4	14	8	38	33.2	18	11.3
2L37009	RL37	8	1/8	12	6	40.4	32.1	14	13.8
2L37010	RL37	8	1/4	14	8	40.4	34.4	18	13.8
2L37012	RL37	10	1/4	14	8	46.6	38	18	16

Y DOBLE TECNOPLIMERO (RL42)

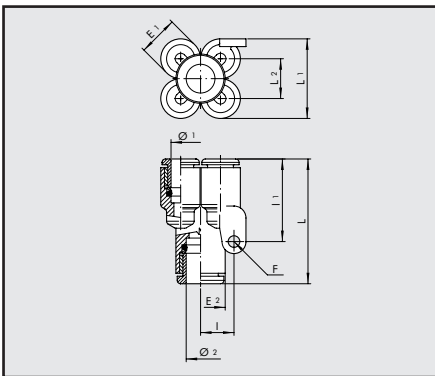

Cod.	Ref.	Ø ₁	Ø ₂	E1	E2	L	L1	L2	I	I1	F
2L42001	RL42	4	4	9.2	9.2	28.8	17.9	8.7	8	21.3	3.3
2L42002	RL42	4	6	9.2	11.3	31.3	17.9	8.7	8	21.3	3.3
2L42004	RL42	6	6	11.3	11.3	33.4	22.6	11.3	9.5	25.6	3.3
2L42005	RL42	6	8	11.3	14	34.8	22.6	11.3	9.5	25.6	3.3

Y DOBLE TECNOPLIMERO INGRESO ROSCADO (RL43)

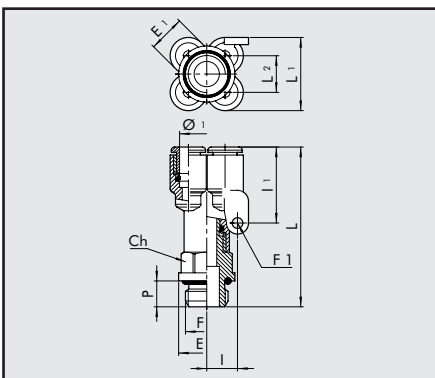

Cod.	Ref.	Ø ₁	F	E1	E	Ch	P	L	L1	L2	I	I1	F1
2L43001	RL43	4	M5	9.2	8	9	4	35.5	17.9	8.7	8	21.3	3.3
2L43002	RL43	4	1/8	9.2	14	12	6	41.6	17.9	8.7	8	21.3	3.3
2L43003	RL43	4	1/4	9.2	18	14	8	44.6	17.9	8.7	8	21.3	3.3
2L43008	RL43	6	1/8	11.3	14	12	6	43.7	22.6	11.3	9.5	25.6	3.3
2L43009	RL43	6	1/4	11.3	18	14	8	46.7	22.6	11.3	9.5	25.6	3.3

COLECTOR MÚLTIPLE TECNOPLIMERO (RL44)

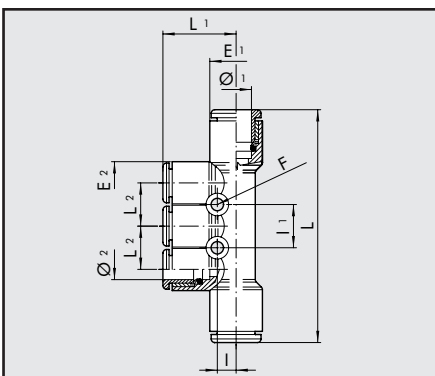

Cod.	Ref.	Ø1	Ø2	E1	E2	L	L1	L2	I	I1	F
2L44001	RL44	6	4	11.3	9.2	53.2	17.2	9.4	4.3	9.4	3.3
2L44003	RL44	8	6	14	11.3	61.4	19.6	11.5	5	11.5	3.3

**COLECTOR MÚLTIPLE ENTRADA
ROSCADA CUERPO EN TECNOPOLIMERO (RL45)**

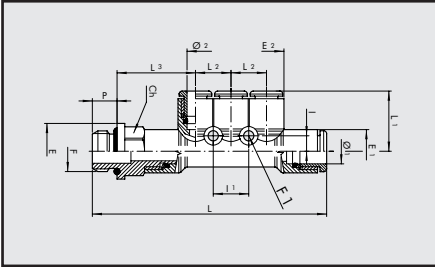

Cód.	Ref.	F	Ø1	Ø2	E1	E2	E	Ch	P	L	L1	L2	L3	I	I1	F1
2L45001	RL45	1/8	6	4	11.3	9.2	14	12	6	63.5	17.2	9.4	21.5	4.3	9.4	3.3
2L45002	RL45	1/4	6	4	11.3	9.2	18	14	8	66.5	17.2	9.4	22.5	4.3	9.4	3.3
2L45007	RL45	1/8	8	6	14	11.3	15	14	6	71.2	19.6	11.5	23	5	11.5	3.3
2L45008	RL45	1/4	8	6	14	11.3	18	14	8	75.6	19.6	11.5	25.4	5	11.5	3.3
2L45009	RL45	3/8	8	6	14	11.3	22	17	9	77.2	19.6	11.5	26	5	11.5	3.3

CURVA DE UNIÓN (RL46)

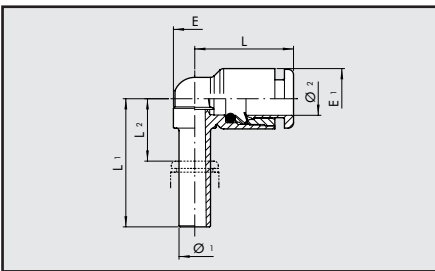

Cód.	Ref.	Ø1	Ø2	L	L1	L2	E	E1
2L46001	RL46	4	4	16	22.5	8.1	6.8	9.2
2L46002	RL46	6	6	18.5	24	8.4	8	11.3
2L46003	RL46	8	8	21.2	28.5	11.3	10	13.8
2L46004	RL46	10	10	23.3	46	27.7	14	16

**CURVA DE UNIÓN PROLONGADA
(RL47)**

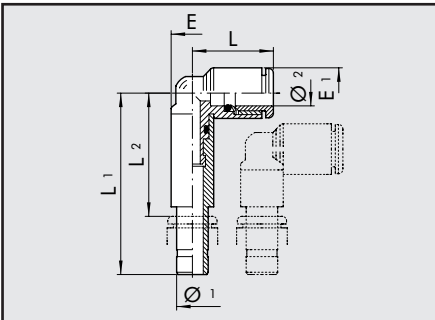

Cód.	Ref.	Ø1	Ø2	L	L1	L2	E	E1
2L47001	RL47	4	4	15.5	36.9	23.4	7.7	9.2
2L47002	RL47	6	6	18.1	40.6	25.9	9.3	11.3
2L47003	RL47	8	8	19.3	44.9	28.8	9.7	13.8

TE UNION INFERIOR (RL48)

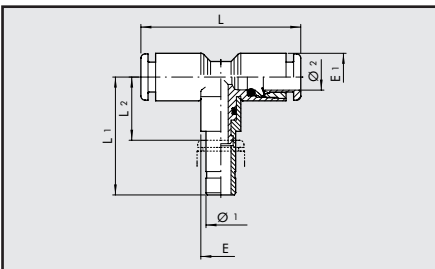

Cód.	Ref.	Ø1	Ø2	L	L1	L2	E	E1
2L48001	RL48	4	4	32	22.5	8.1	6.8	9.2
2L48002	RL48	6	6	37	32	16.4	9.7	11.3
2L48003	RL48	8	8	42.4	28.5	11.3	10	13.8
2L48004	RL48	10	10	46.6	46	27.7	14	16

TE UNION LATERAL (RL49)

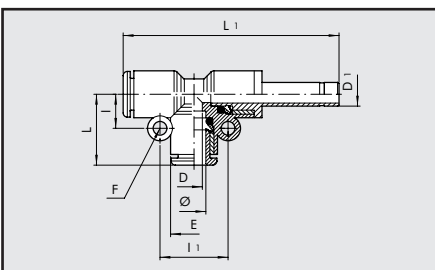

Cód.	Ref.	Ø	L	L1	I	I1	E	D	D1	F
2L49001	RL49	4	16.7	47.4	7.2	14.4	9.2	2.5	4	3.3
2L49003	RL49	6	19	52.5	8.2	16.4	11.3	4.2	6	3.3
2L49004	RL49	8	21.4	58.4	9.6	19.2	13.8	6.2	8	3.3
2L49005	RL49	10	24.1	68.2	10.9	21.8	16	8.5	10	3.3
2L49006	RL49	12	25.8	74.1	12.5	25	19.5	10.5	12	3.3



CARTUCHOS Y ACCESORIOS

CARTUCHO EN LATÓN CON ROSCA (R26)

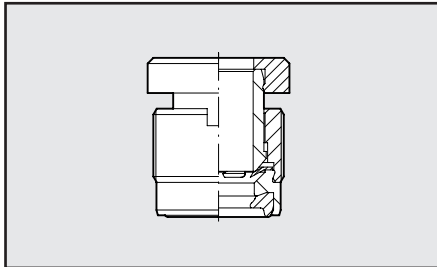

Cód.	Ref.	Ø	Par de apriete Sobre sede en mat.plástico (Nm)	Par de apriete sobre sede metálica (Nm)
SERIE R				
2026A02	R26	3	0.6	0.8
2026A01	R26	3.17	0.6	0.8
2026001	R26	4	0.8	1
2026002	R26	5	0.8	1.5
2026003	R26	6	0.8	1.2
2026004	R26	8	1	1.8
2026005	R26	10	0.8	2
2026006	R26	12	0.8	2

SEDE CARTUCHO R26 Ø 3-3.17-4-6-8

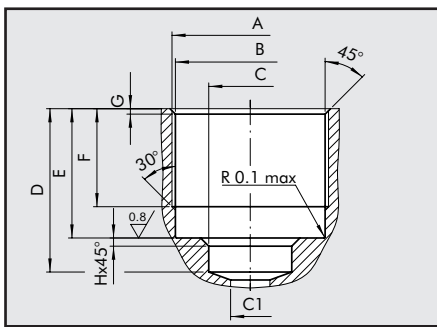

Ref.	Ø	A	B	C	C1	D	E	F	G	H
SE.CA. R26	3-3.17	M7x0,75	Ø6,5 ^{+0,1} ₀	Ø4,5 ^{+0,12} ₀	Ø4 max	10,5 ^{+0,3} ₀	9,5 ^{+0,1} _{0,3}	7 ^{+0,20}	0,5	-
SE.CA. R26	4	M9,5x0,75	Ø9 ^{+0,10} ₀	Ø4,1 ^{+0,10} ₀	Ø3 max	12 ⁺⁰ _{-0,20}	9,5 ^{+0,15} _{-0,05}	7,5 ^{+0,20}	0,4	0,6
SE.CA. R26	6	M11,5x0,75	Ø11 ^{+0,10} ₀	Ø6,1 ^{+0,10} ₀	Ø5 max	12 ^{+0,1}	9,5 ^{+0,1}	7,5 ^{+0,20}	0,4	0,6
SE.CA. R26	8	M13,5x0,75	Ø13 ^{+0,10} ₀	Ø8,1 ^{+0,10} ₀	Ø7 max	15 ⁺⁰ _{-0,20}	10,5 ^{+0,15} _{-0,05}	8,5 ^{+0,20}	0,4	0,6

SEDE CARTUCHO R26 Ø 5-10-12

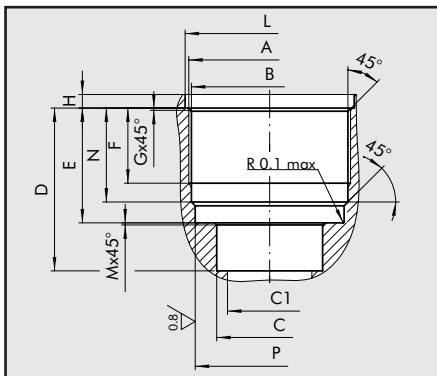

Ref.	Ø	A	B	C	C1	D	E	F	G	H
SE.CA. R26	5	M10,5x0,75	Ø10 ^{+0,1} ₀	Ø5,1 ^{+0,15} ₀	Ø4 max	11,8 ^{+0,1}	8,9 ^{+0,10} ₀	5,8 ^{+0,3} ₀	0,3	0,9 ⁺⁰ _{-0,3}
SE.CA. R26	10	M15,5x0,75	Ø15 ^{+0,1} ₀	Ø10,1 ^{+0,15} ₀	Ø9 max	15,6 ^{+0,1}	11 ^{+0,05} ₀	7,5 ^{+0,3} ₀	0,3	1,3 ⁺⁰ _{-0,3}
SE.CA. R26	12	M18x1	Ø17,5 ^{+0,05} _{-0,1}	Ø12,1 ^{+0,05} _{-0,15}	Ø11 max	18 ^{+0,1}	12 ^{+0,05} ₀	6,8 ^{+0,3} ₀	0,6	1,3 ⁺⁰ _{-0,3}

L	M	N	P
Ø11,2 ^{+0,12} _{+0,02}	0,1	7,8 ^{+0,05}	Ø9,7 ^{+0,05}
Ø16,2 ^{+0,1} _{-0,05}	0,2	9 ^{+0,05}	Ø14,9 ^{+0,10} ₀
Ø18,8 ^{+0,1} ₀	0,2	9,75 ⁺⁰ _{-0,15}	Ø17 ^{+0,1} ₀

UTIL DE PREPARACIÓN SEDE R26

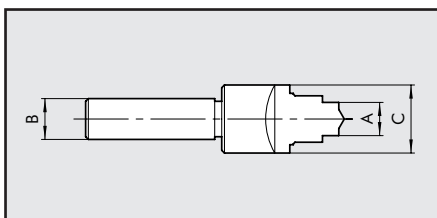

Cód.	Ref.	A	B	C
2025010	UT.SE. R26 3-3.17	4,5	Ø 10	Ø 10
2025011	UT.SE. R26 4	4,1	Ø 12	Ø 15
2025012	UT.SE. R26 5	5,1	Ø 15	Ø 19
2025013	UT.SE. R26 6	6,1	Ø 16	Ø 19
2025014	UT.SE. R26 8	8,1	Ø 16	Ø 21
2025015	UT.SE. R26 10	10,1	Ø 18	Ø 25
2025016	UT.SE. R26 12	12,1	Ø 15	Ø 25

MACHO PARA SEDE CARTUCHO R26

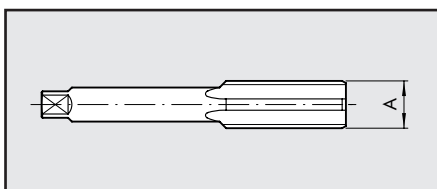

Cód.	Ref.	Ø	A
2025020	MA R26 3-3.17	3-3.17	M7x0,75
2025021	MA R26 4	4	M9,5x0,75
2025022	MA R26 5	5	M10,5x0,75
2025023	MA R26 6	6	M11,5x0,75
2025024	MA R26 8	8	M13,5x0,75
2025025	MA R26 10	10	M15,5x0,75
2025026	MA R26 12	12	M18x1

CARTUCHO DE LATÓN A COMPRESION (R27)

Cód. Ref. Ø

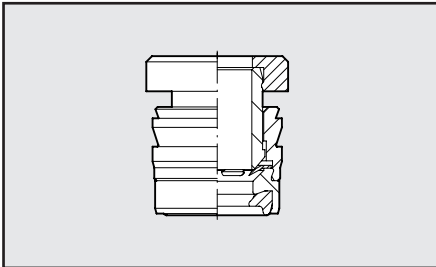

SERIE R

2027001	R27	4
2027002	R27	5
2027003	R27	6
2027004	R27	8
2027005	R27	10
2027006	R27	12

SEDE CARTUCHO R27 Ø 4-6-8

Ref. Ø A B C C1 D E F G

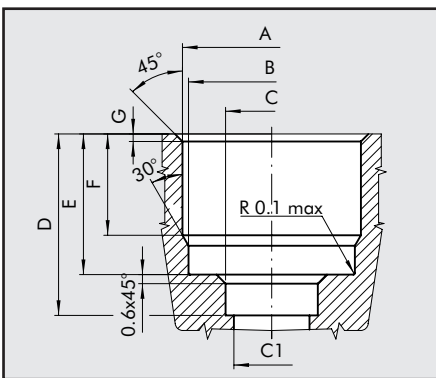

Para aluminio

SE.CA. R27 4	4	Ø9,2 ^{+0,10} _{-0,10}	Ø9 ^{+0,10} ₋₀	Ø4,1 ^{+0,10} ₋₀	Ø3 max	12 ⁺⁰ _{-0,20}	9,3 ⁺⁰ _{-0,10}	6,7 ^{+0,10} ₋₀	0,5
SE.CA. R27 6	6	Ø11,3 ^{+0,08} _{-0,08}	Ø11 ^{+0,10} ₋₀	Ø6,1 ^{+0,10} ₋₀	Ø5 max	12 ⁺⁰ _{-0,20}	9,3 ⁺⁰ _{-0,10}	6,7 ^{+0,10} ₋₀	0,5
SE.CA. R27 8	8	Ø13,3 ^{+0,08} _{-0,08}	Ø13 ^{+0,10} ₋₀	Ø8,1 ^{+0,10} ₋₀	Ø7 max	15 ⁺⁰ _{-0,20}	10,3 ⁺⁰ _{-0,10}	7,7 ^{+0,10} ₋₀	0,5

Para material plástico

SE.CA. R27 4	4	*Ø9,2 ^{+0,10} _{-0,10}	Ø9 ^{+0,10} ₋₀	Ø4,1 ^{+0,10} ₋₀	Ø3 max	12 ⁺⁰ _{-0,20}	9,3 ⁺⁰ _{-0,10}	6,7 ^{+0,10} ₋₀	0,5
SE.CA. R27 6	6	*Ø11,2 ^{+0,10} _{-0,10}	Ø11 ^{+0,10} ₋₀	Ø6,1 ^{+0,10} ₋₀	Ø5 max	12 ⁺⁰ _{-0,20}	9,3 ⁺⁰ _{-0,10}	6,7 ^{+0,10} ₋₀	0,5
SE.CA. R27 8	8	*Ø13,2 ^{+0,10} _{-0,10}	Ø13 ^{+0,10} ₋₀	Ø8,1 ^{+0,10} ₋₀	Ø7 max	15 ⁺⁰ _{-0,20}	10,3 ⁺⁰ _{-0,10}	7,7 ^{+0,10} ₋₀	0,5

* N.B.: el diametro de interferencia es puramente indicativo ,dependiendo del tipo de material plastico utilizado y del espesor. Se recomienda realizar pruebas practicas de montaje

SEDE CARTUCHO R27 Ø 5-10-12

Ref. Ø A B C D E F H L M

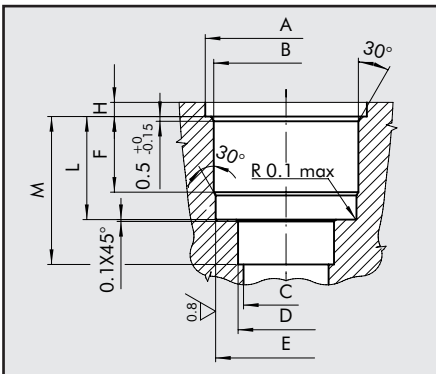

Para material plástico

SE.CA. R27	5	*Ø12,1 ^{+0,15} ₋₀	Ø10,2 ⁺⁰ _{-0,10}	Ø4 ^{MAX}	Ø5,1 ^{+0,15} ₋₀	Ø9,7 ^{+0,05} ₋₀	6 ^{+0,2} ₋₀	1,2 ⁻⁰ _{-0,2}	8,75 ⁻⁰ _{-0,1}	11,8 ^{+0,10}
SE.CA. R27	10	*Ø17,1 ^{+0,15} ₋₀	Ø15,15 ⁺⁰ _{-0,08}	Ø9 ^{MAX}	Ø10,15 ^{+0,1} ₋₀	Ø14,9 ^{+0,05} ₋₀	8 ^{+0,2} ₋₀	1,5 ⁻⁰ _{-0,2}	10,9 ⁻⁰ _{-0,1}	15,6 ^{+0,10}
SE.CA. R27	12	*Ø19,7 ^{+0,15} ₋₀	Ø17,55 ⁺⁰ _{-0,08}	Ø11 ^{MAX}	Ø12,15 ^{+0,1} ₋₀	Ø17,1 ^{+0,05} ₋₀	9 ^{+0,2} ₋₀	1,5 ⁻⁰ _{-0,2}	11,85 ⁻⁰ _{-0,1}	18 ^{+0,10}

Aluminio

SE.CA. R27	5	Ø12,1 ^{+0,15} ₋₀	Ø10,3 ⁺⁰ _{-0,08}	Ø4 ^{MAX}	Ø5,1 ^{+0,15} ₋₀	Ø9,7 ^{+0,05} ₋₀	6 ^{+0,2} ₋₀	1,2 ⁻⁰ _{-0,2}	8,75 ⁻⁰ _{-0,1}	11,8 ^{+0,10}
SE.CA. R27	10	Ø17,1 ^{+0,15} ₋₀	Ø15,4 ⁺⁰ _{-0,08}	Ø9 ^{MAX}	Ø10,15 ^{+0,1} ₋₀	Ø14,9 ^{+0,05} ₋₀	8 ^{+0,2} ₋₀	1,5 ⁻⁰ _{-0,2}	10,9 ⁻⁰ _{-0,1}	15,6 ^{+0,10}
SE.CA. R27	12	Ø19,7 ^{+0,15} ₋₀	Ø17,8 ⁺⁰ _{-0,08}	Ø11 ^{MAX}	Ø12,15 ^{+0,1} ₋₀	Ø17,1 ^{+0,05} ₋₀	9 ^{+0,2} ₋₀	1,5 ⁻⁰ _{-0,2}	11,85 ⁻⁰ _{-0,1}	18 ^{+0,10}

* N.B.: el diametro de interferencia es puramente indicativo ,dependiendo del tipo de material plastico utilizado y del espesor. Se recomienda realizar pruebas practicas de montaje

UTIL DE PREPARACIÓN SEDE R27

Cód. Ref. A B C

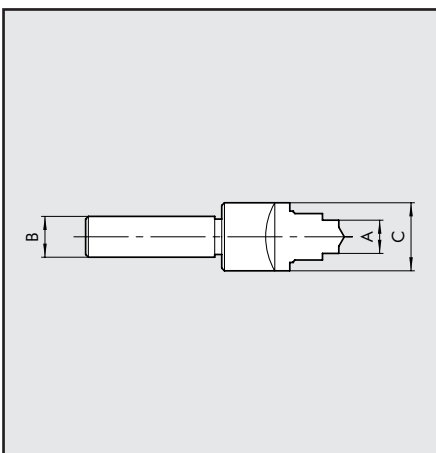

Aluminio

2027021	UT.SE. R27 AL. 4	4,1	Ø 10	11.5
2027022	UT.SE. R27 AL. 5	5,1	Ø 12	16
2027023	UT.SE. R27 AL. 6	6,1	Ø 12	13.5
2027024	UT.SE. R27 AL. 8	8,1	Ø 12	15.5
2027025	UT.SE. R27 AL. 10	10,1	Ø 16	20
2027026	UT.SE. R27 AL. 12	12,1	Ø 16	22

Material plástico

2027011	UT.SE. R27 P. 4	4,1	Ø 10	11.5
2027012	UT.SE. R27 P. 5	5,1	Ø 12	16
2027013	UT.SE. R27 P. 6	6,1	Ø 12	13.5
2027014	UT.SE. R27 P. 8	8,1	Ø 12	15.5
2027015	UT.SE. R27 P. 10	10,1	Ø 16	20
2027016	UT.SE. R27 P. 12	12,1	Ø 16	22



R17 – LLAVE DE DESMONTAJE

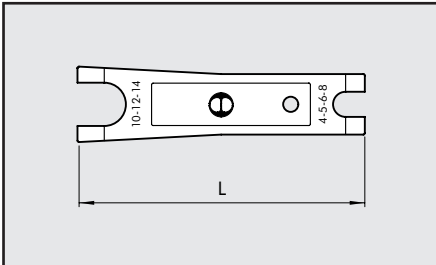

Cód.	Ref.	L	Ø TUBO	NOTAS
2L17001	RL40	140	da ø 3 a ø 10	PARA RACORES R Y RAC. FOX
2017001	R40	95.0	da ø 4 a ø 14	SOLO PARA RACORES R

R41 – LLAVE PARA CARTUCHO R26

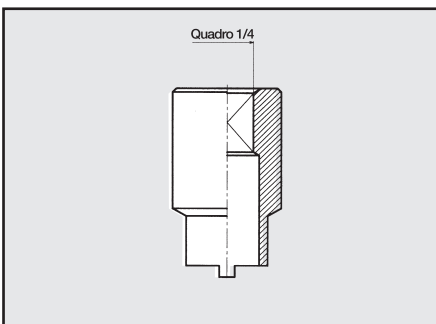

Cód.	Ref.			
2041001	R41	4		
2041002	R41	5		
2041003	R41	6		
2041004	R41	8		
2041005	R41	10		
2041006	R41	12		

NOTAS

Multiple blank lines provided for notes, currently empty.